

# RynoWorx

## Operator's Manual

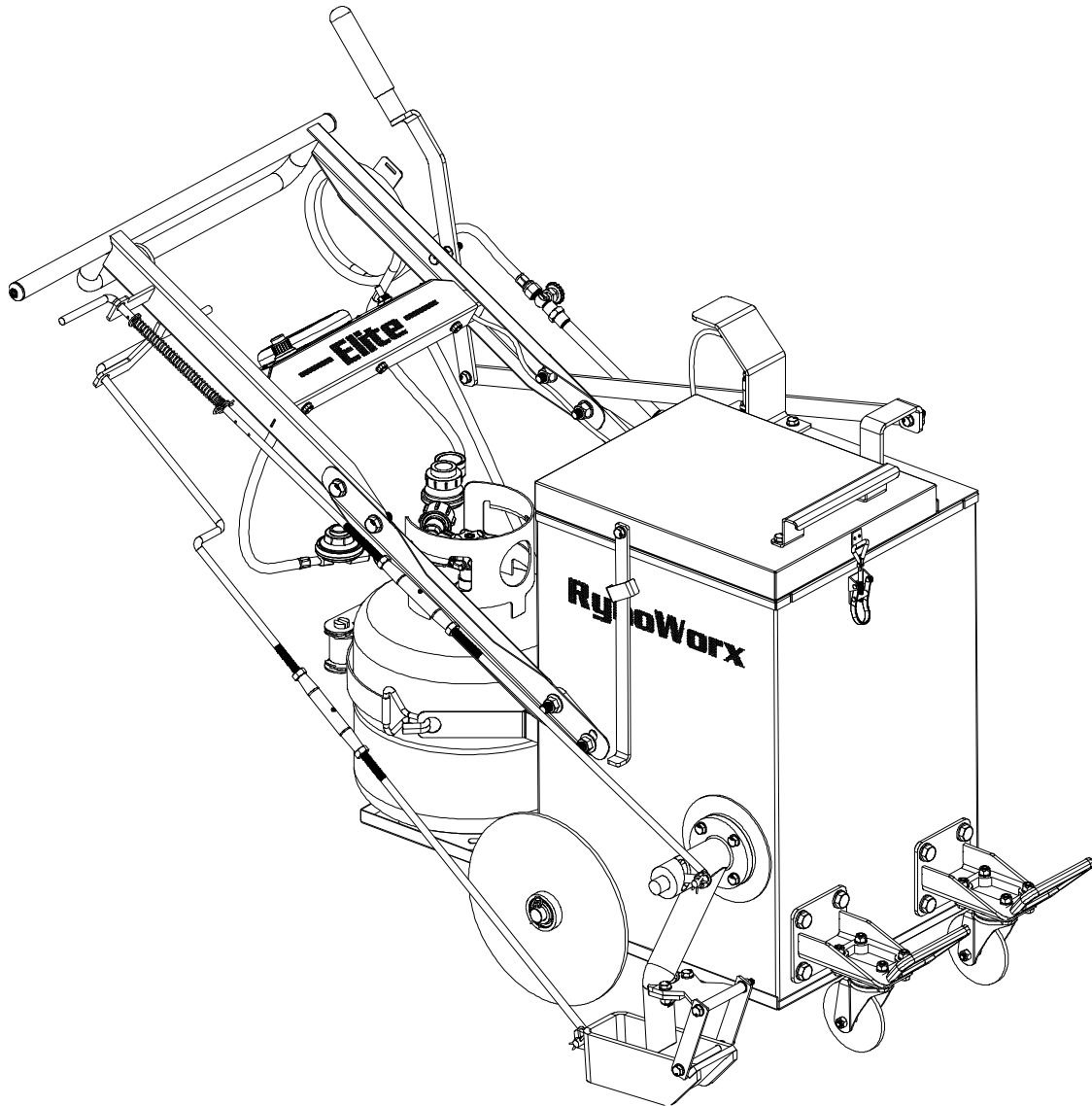

**Model: RY10MA-Elite**

**MPN: RA-MLT-0014**

10 Gallon Direct Fire Melter Applicator  
Burner Model with Flame-Out Sensor

U.S. Patent No. 9,739,021

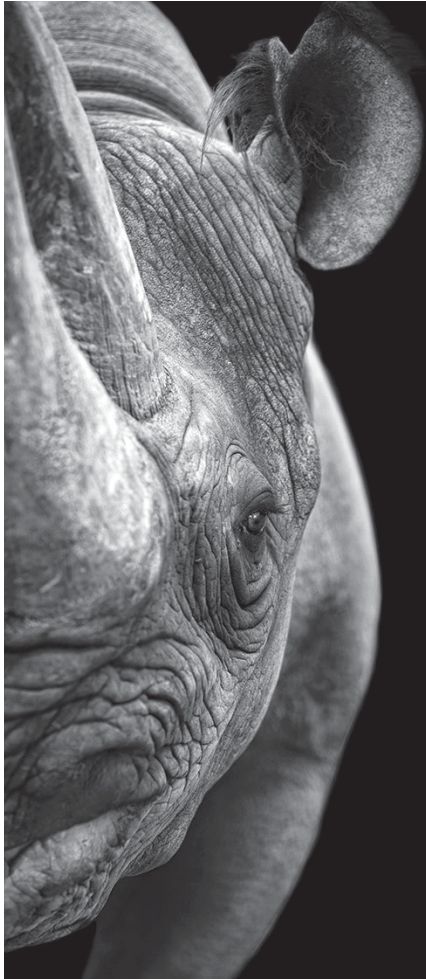

# NEED HELP? WE ARE HERE FOR YOU!



**Facebook Messenger**

support@rynoworx.com



**WhatsApp Messaging**

519-404-9775



**Website Chat**

rynoworx.com/support



**Email**

support@rynoworx.com



**Phone**

855-382-9611



**RynoWorx®**

RYNOWORX.COM

# Warning

⚠ A flame out valve bypass (RC-CAP-0008) has been provided with this product (shown below).

⚠ This cap can be used to temporarily bypass the flameout valve and keep the burner running in the event of a thermocouple failure. It is designed for emergency use only and should be removed immediately upon work completion.

⚠ **\*\*\*USE OF THIS BYPASS IS AT YOUR OWN RISK\*\*\***

⚠ **\*\*\*DO NOT LEAVE THE EQUIPMENT UNATTENDED WHILE BYPASS INSTALLED\*\*\***

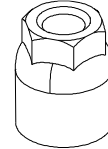

⚠ Read all instructions and warnings in this manual before attempting to operate this equipment.

⚠ This equipment is designed for outdoor use only.

⚠ Be sure to always wear personal protective equipment when operating this equipment.

⚠ Improper assembly may be dangerous. Please follow the assembly instructions in this manual. Make sure all parts are assembled and hardware is fully tightened before using. Make sure that there are no leaks in the liquid propane cylinder connection or lines.

⚠ Do not operate the equipment if a gas leak is present. (check for leaks and connections with every use)

⚠ Do not attempt to disconnect the gas regulator from the tank or any gas fitting while the equipment is in use.

⚠ A dented or rusty liquid propane tank may be hazardous and should be checked by your liquid propane supplier. Do not use a liquid propane tank with a damaged valve.

⚠ Ensure that your propane cylinder is within its expiry date for your local jurisdiction. If the tank has expired it must be properly requalified to continue using.

⚠ Ensure that your propane cylinder is within its expiry date for your local jurisdiction. The manufacturing date is stamped on the collar of the tank. If the tank has expired it must be properly requalified.

⚠ Do not store spare liquid propane cylinders within 10 feet (3m) of this equipment.

⚠ Do not store or use gasoline or other flammable liquids or vapors within 25 feet (8m) of this equipment.

⚠ Before servicing, make sure the unit is fully cooled and the liquid propane cylinder is disconnected.

⚠ Only genuine RynoWorx replacement parts should be used for any replacements or repairs. Do not attempt to modify or alter this product in any way.

⚠ Do not attempt to make any repairs to gas carrying, gas burning, igniter components or structural components. Your actions, if you fail to follow this warning, may cause a fire, an explosion, or structural failure resulting in serious personal injury or death as well as damage to property.

⚠ This equipment should only be used with "Direct Fire" hot melt crack sealant.

⚠ Failure to follow these instructions could result in fire or explosion which could cause property damage, personal injury or death.

No	P/N	Qty	Description
1	RA-BAS-0059	1	Valve Control Arm Assembly - MA-V4
2	RA-BAS-0060	1	Shoe Control Arm Assembly - MA-V4
3	RA-BAS-0063	1	On-the-Fly Agitation Sub-Assembly - MA-V4
4	RC-GCM-0049	1	Propane Tank Y Splitter / Adaptor
5	RA-GCM-0015	1	MA Torch Complete Assembly
6	RC-STR-0001	1	Propane Tank Ratchet Strap
7	RC-FAB-0147	1	Thermometer Guard - MA-V4
8	RC-FAB-0133	1	Tank Spacer - MA-V4
9	RC-FAB-0151	1	Lid Handle - MA-V4
10	RC-FAB-0132	1	Tank Shelf - MA-V4
11	RC-FAB-0101	1	Melter Lid Support Slider
12	RC-FAB-0130	1	Kettle Body - MA-V4
13	RC-LCH-0001	1	Latch - 10 Gallon Kettle
14	RA-BAS-0064	1	Elite Handle Bar Assembly with Dash, Thermometer, & Burner
15	RA-WHL-0026	2	Rear Wheel Assembly with Bearings - Melter Applicator - V2
16	RA-BAS-0071	1	Valve and Shoe Sub Asy
17	RA-WHL-0024	2	Elite Front Caster Assembly
18	RC-FAB-0143	1	Agitation Sweep Bar - MA-V4

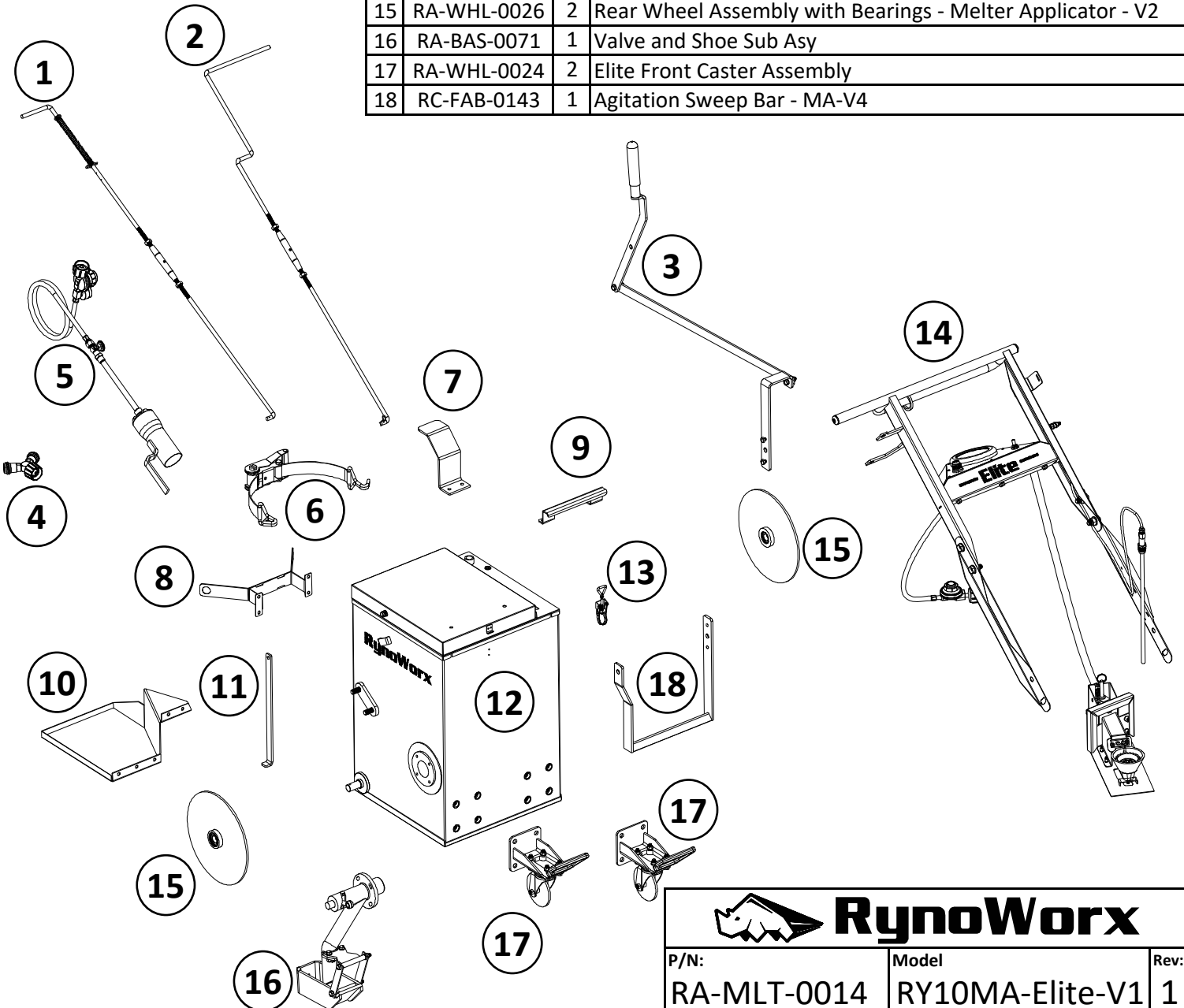

**RynoWorx**

P/N:	Model	Rev:
RA-MLT-0014	RY10MA-Elite-V1	1

Description:  
 RY10MA-Elite - 10 Gallon Burner Fired Melter  
 Applicator - Complete Assembly - Version 1

- **Introduction**

---

### **Forward**

Thank you very much for purchasing RynoWorx crack maintenance equipment. We pride ourselves in being different from other equipment manufacturers with a relentless focus on innovation, simplicity, and quality.

RY Series Melter / Applicators are designed to effectively melt and apply direct-fire type crack sealant to joints and cracks found in hard aggregate surfaces. This melter is powered by a liquid propane gas burner, which effectively melts crack sealants within the kettle.

This melter was designed to be used with 'Direct Fire' crack sealants only. Please be sure to purchase the correct material to ensure safe and effective operation.

**Within this document are complete instructions for how to assemble, use and care for your equipment. Please make sure you read and follow all instructions provided.**

Within this document you will find the following resources:

- **Assembly/ Setup Instructions** – These instructions will assist you in assembling and preparing your melter for first time use.
- **Operation Guide** – This guide will explain the controls and functions of the melter and how to use them.
- **Maintenance Guide** – This guide will provide you with suggested maintenance tips and techniques to ensure proper function and optimal performance.
- **Troubleshooting Guide** – This guide will provide you with the most commonly reported problems, possible causes, and known solutions.

# 1. Tank Shelf

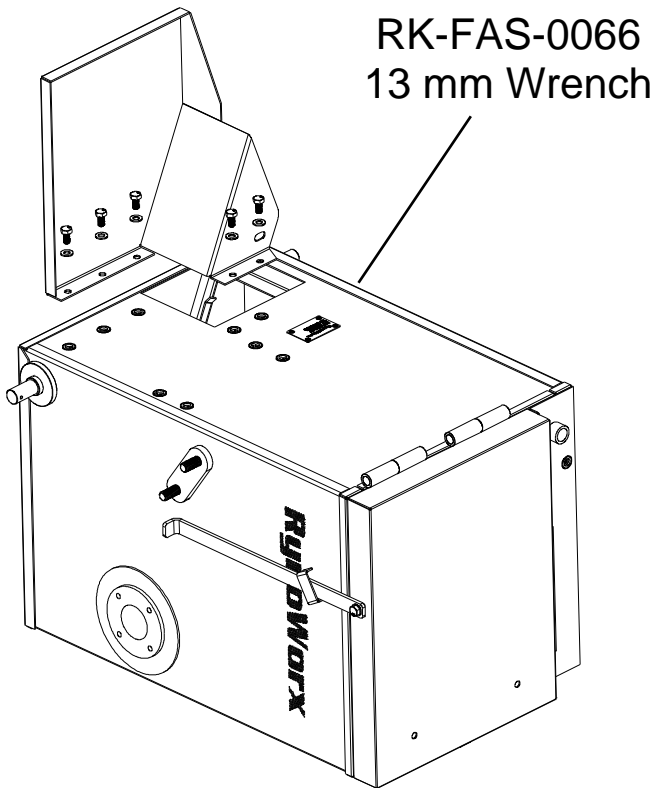

# 2. Tank Spacer

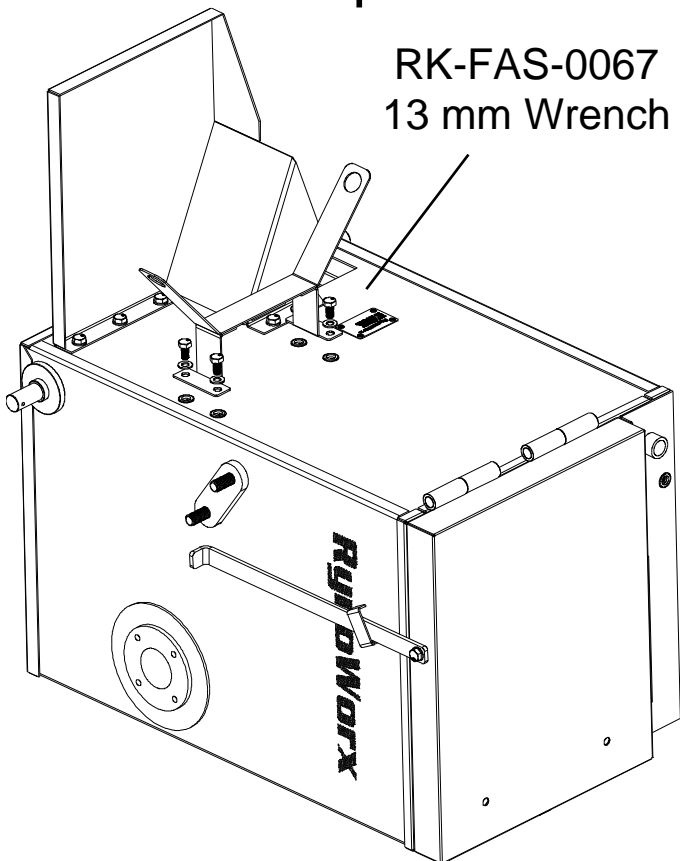

### 3. Rear Wheels

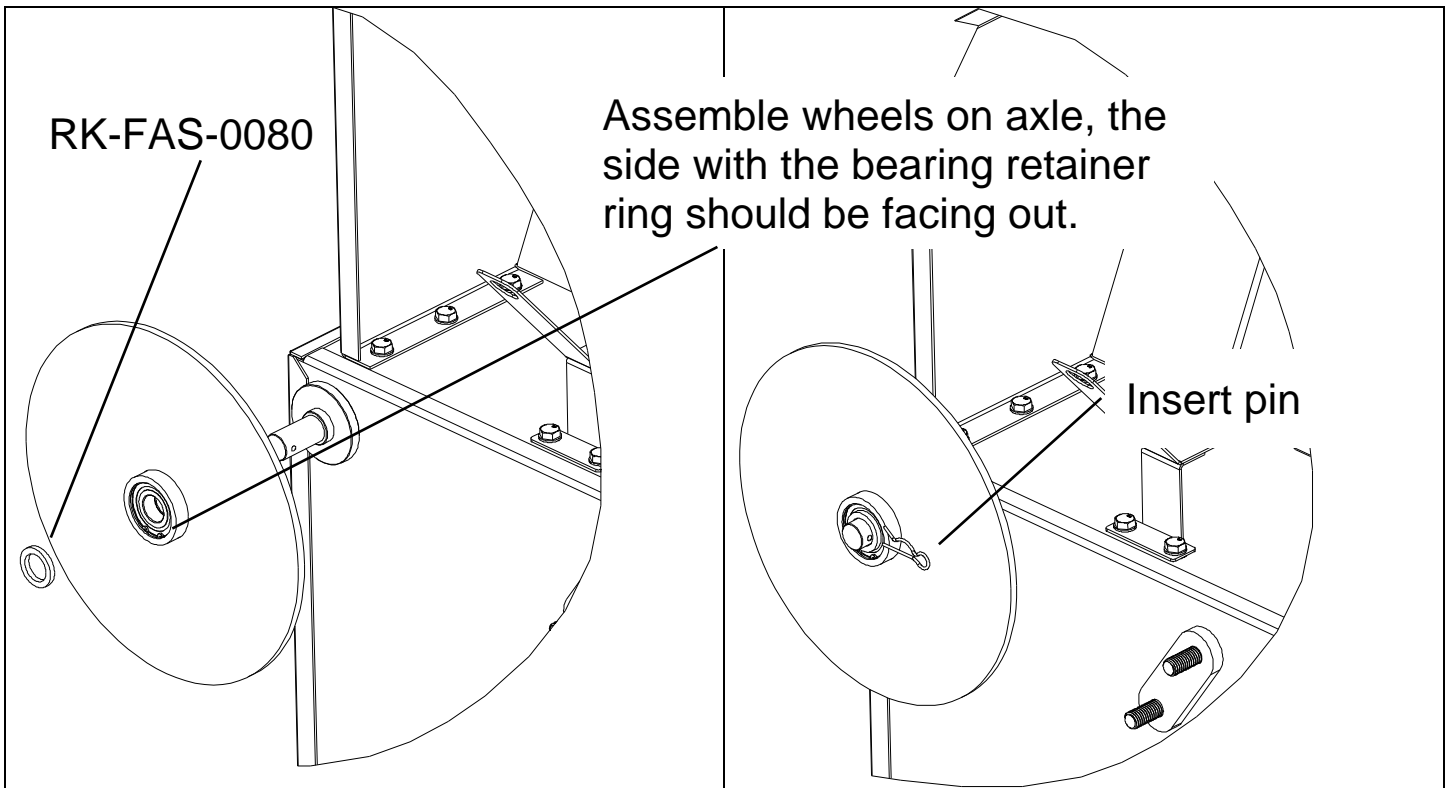

### 4. Casters

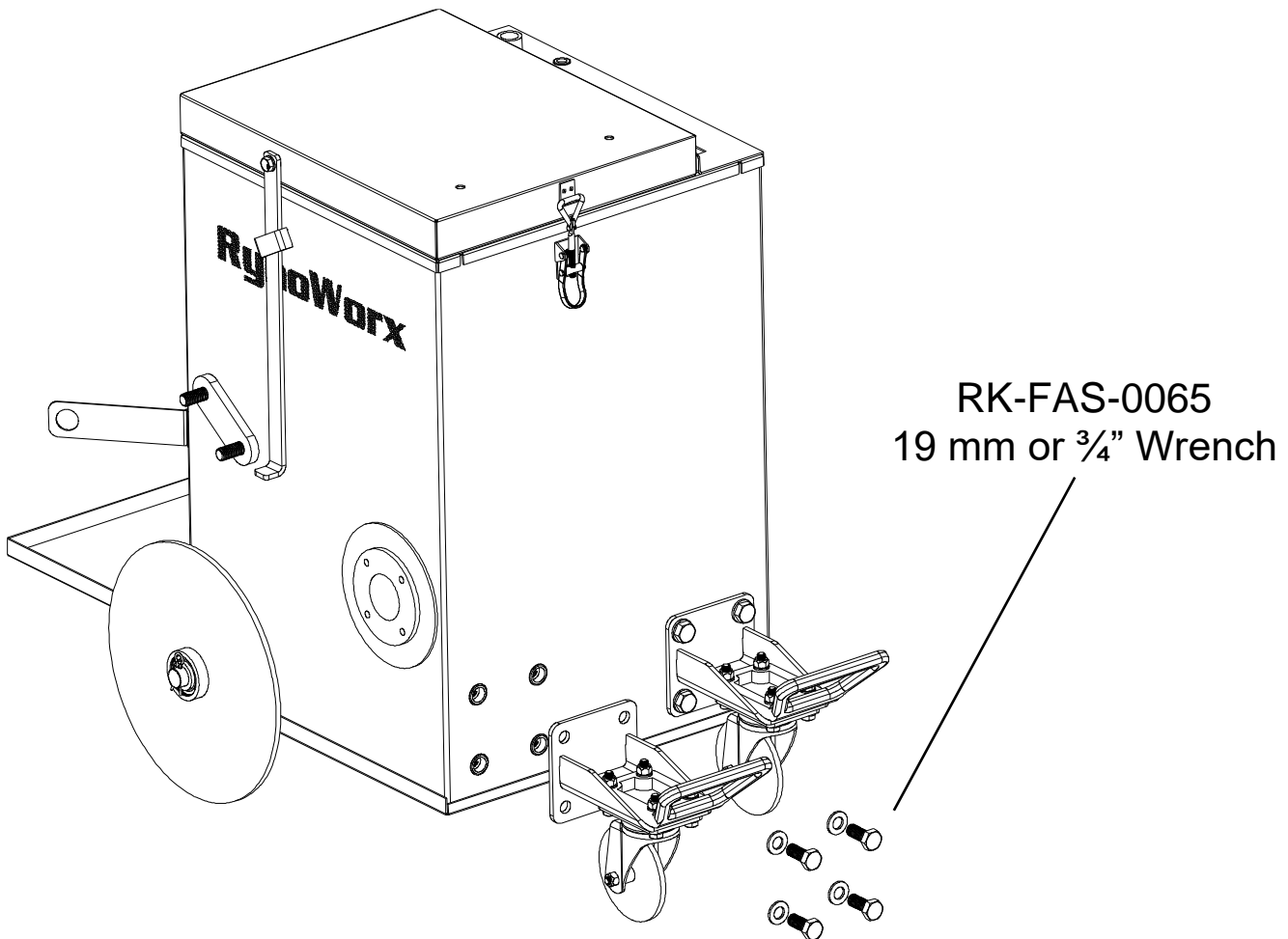

## 5. Valve and Shoe

RK-FAS-0069  
13 mm Wrench

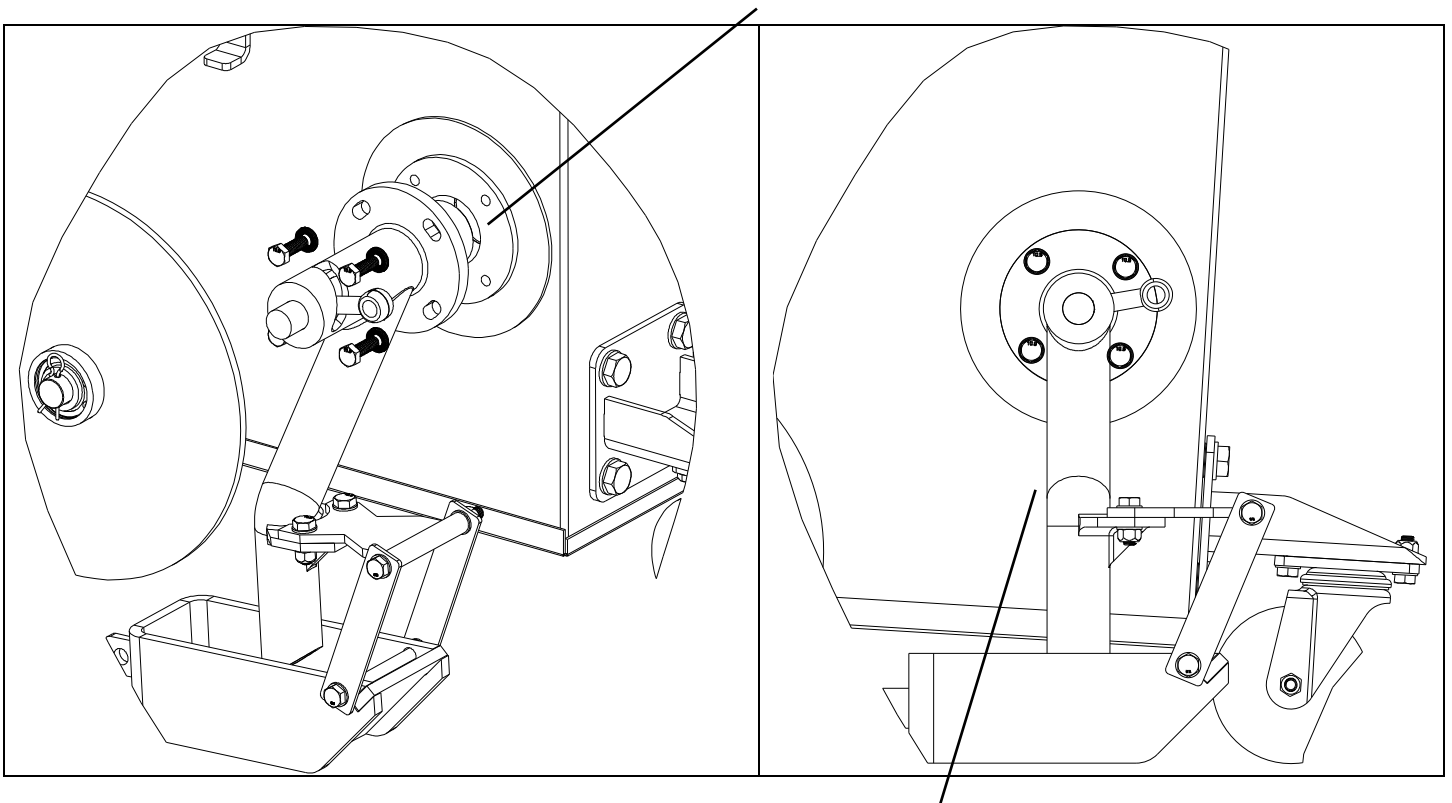

Valve should be aligned so it is perpendicular to the ground before the bolts are tightened

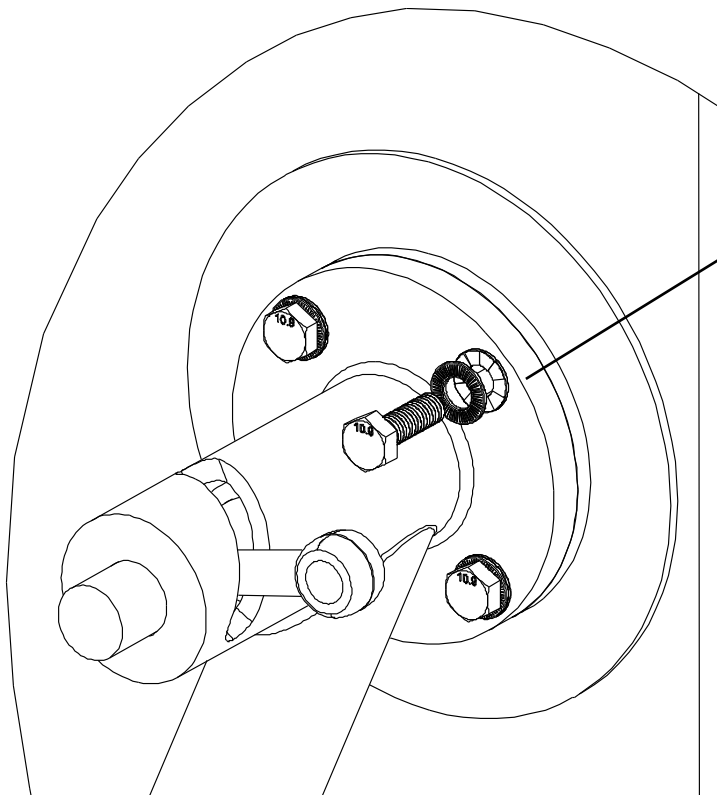

⚠ The lock washers provided for the valve are shipped in pairs. Use 1 pair for each bolt with the wedged surfaces on the washers mated together (same orientation that the washers come paired in).

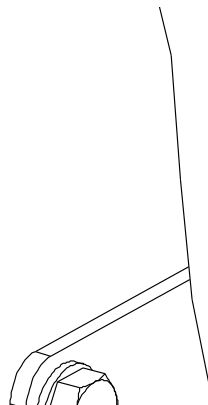



## 6. Burner and Handle Bars

⚠ Use caution when assembling the handle bar assembly as the burner ships connected to the dash.

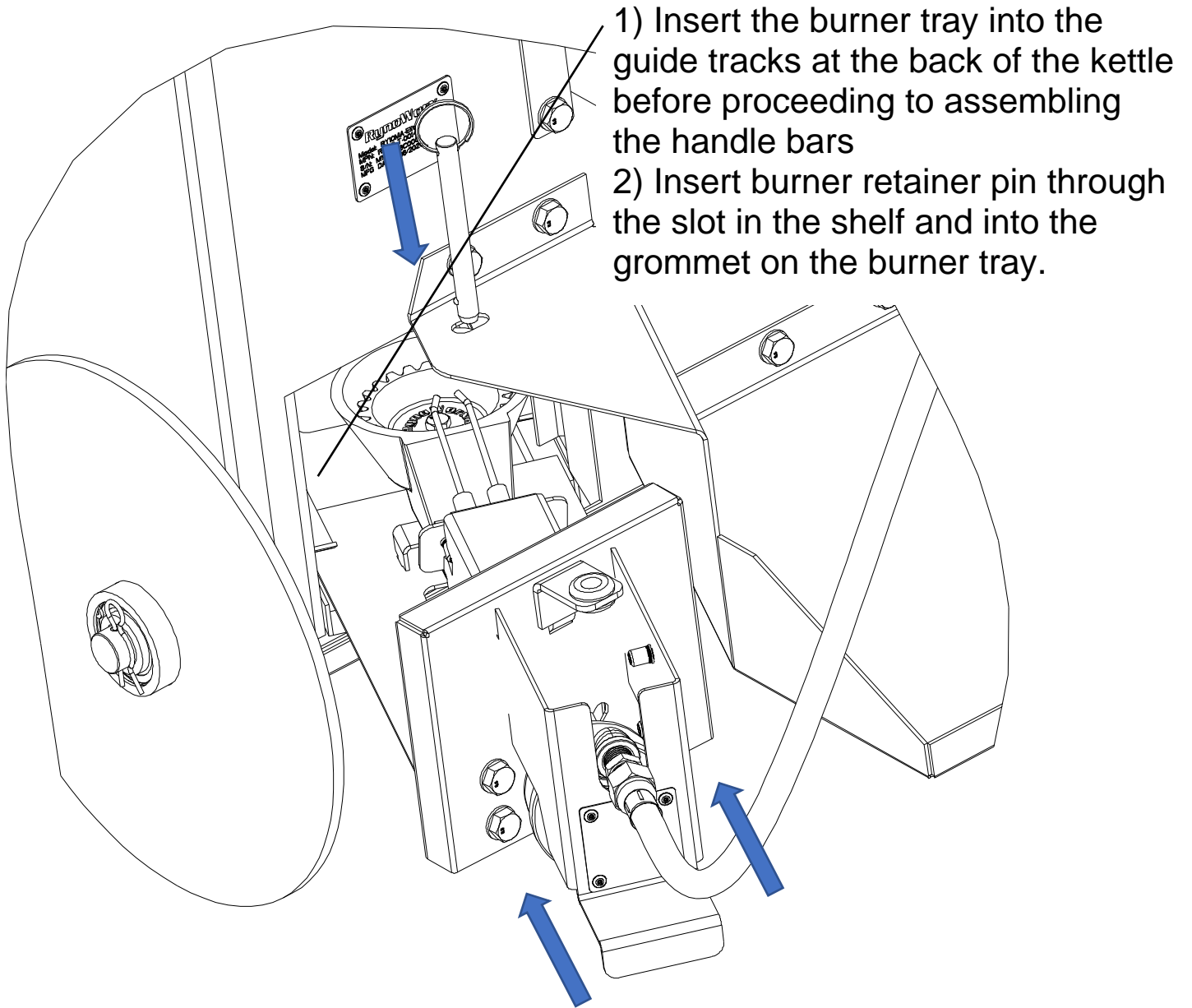

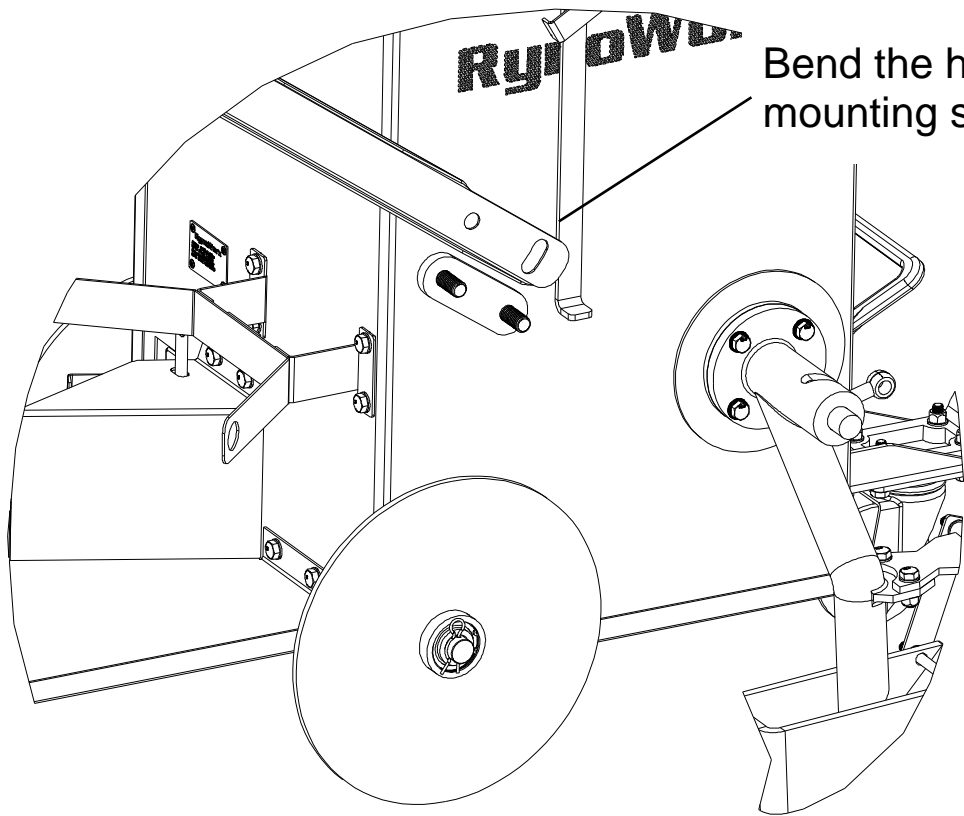

Bend the handle bars over the mounting studs one side at a time

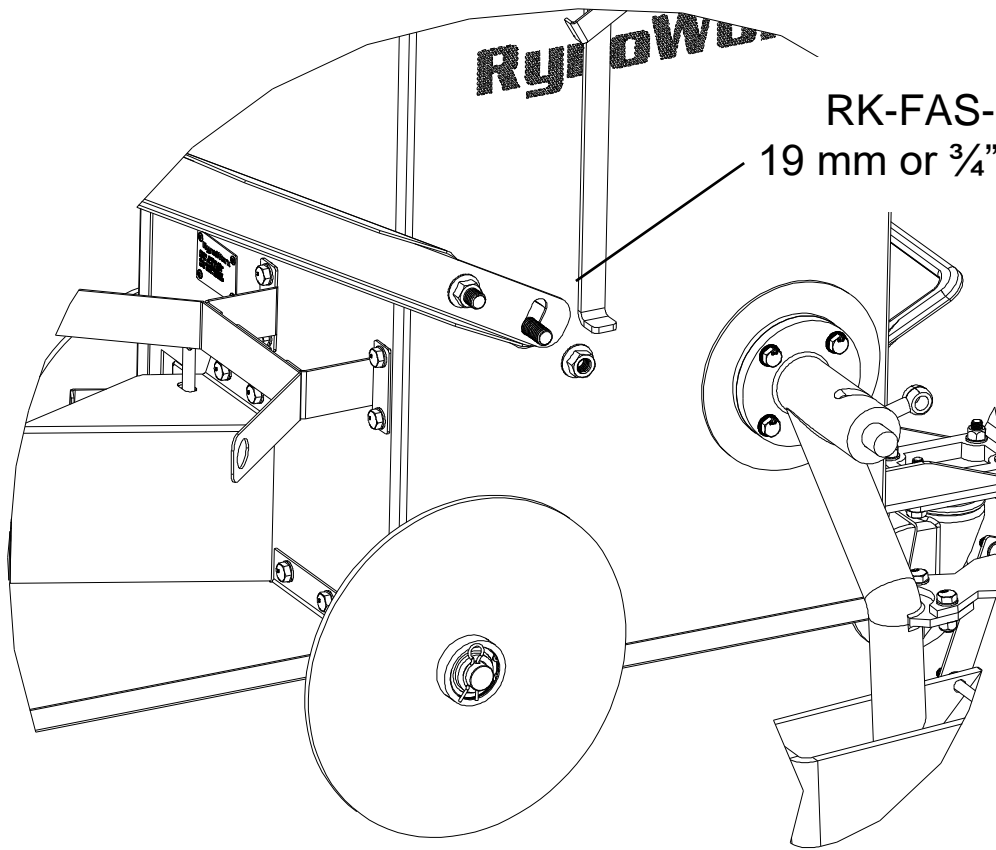

RK-FAS-0083  
19 mm or 3/4" Wrench

Tighten the handle bar nuts so that they are snug, nuts will be fully tightened in the set-up section.

## 7. Thermometer Probe

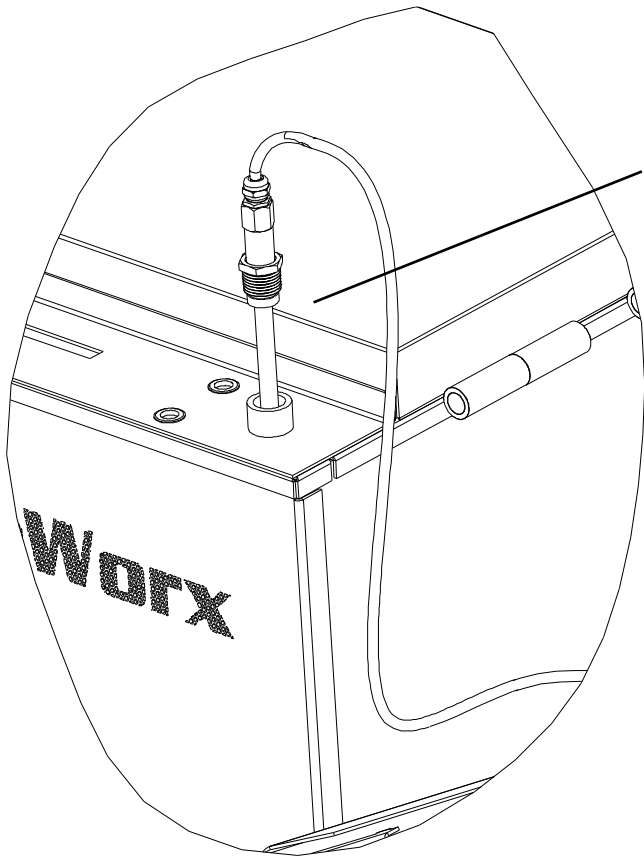

Thread the thermometer probe into the kettle

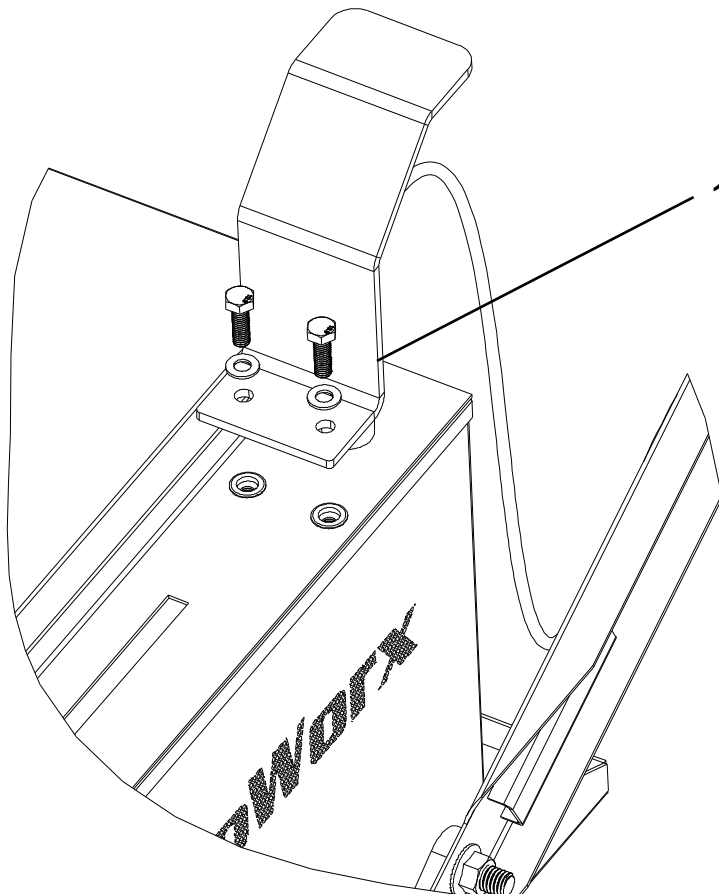

RK-FAS-0071  
13 mm Wrench

## 8. On-the-Fly Agitation

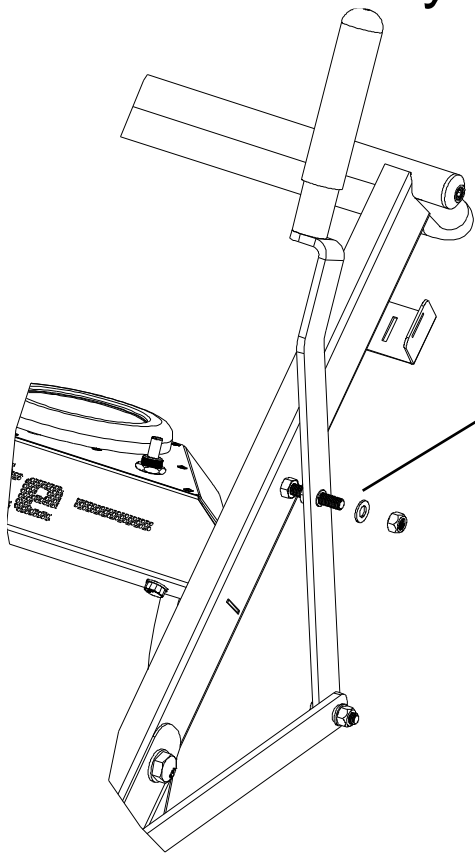

Attach the agitation handle with the hardware preassembled on the handle bars

Remove the 2 bolts on the agitation connector handle and insert the handle into the slot and over the stud inside the kettle

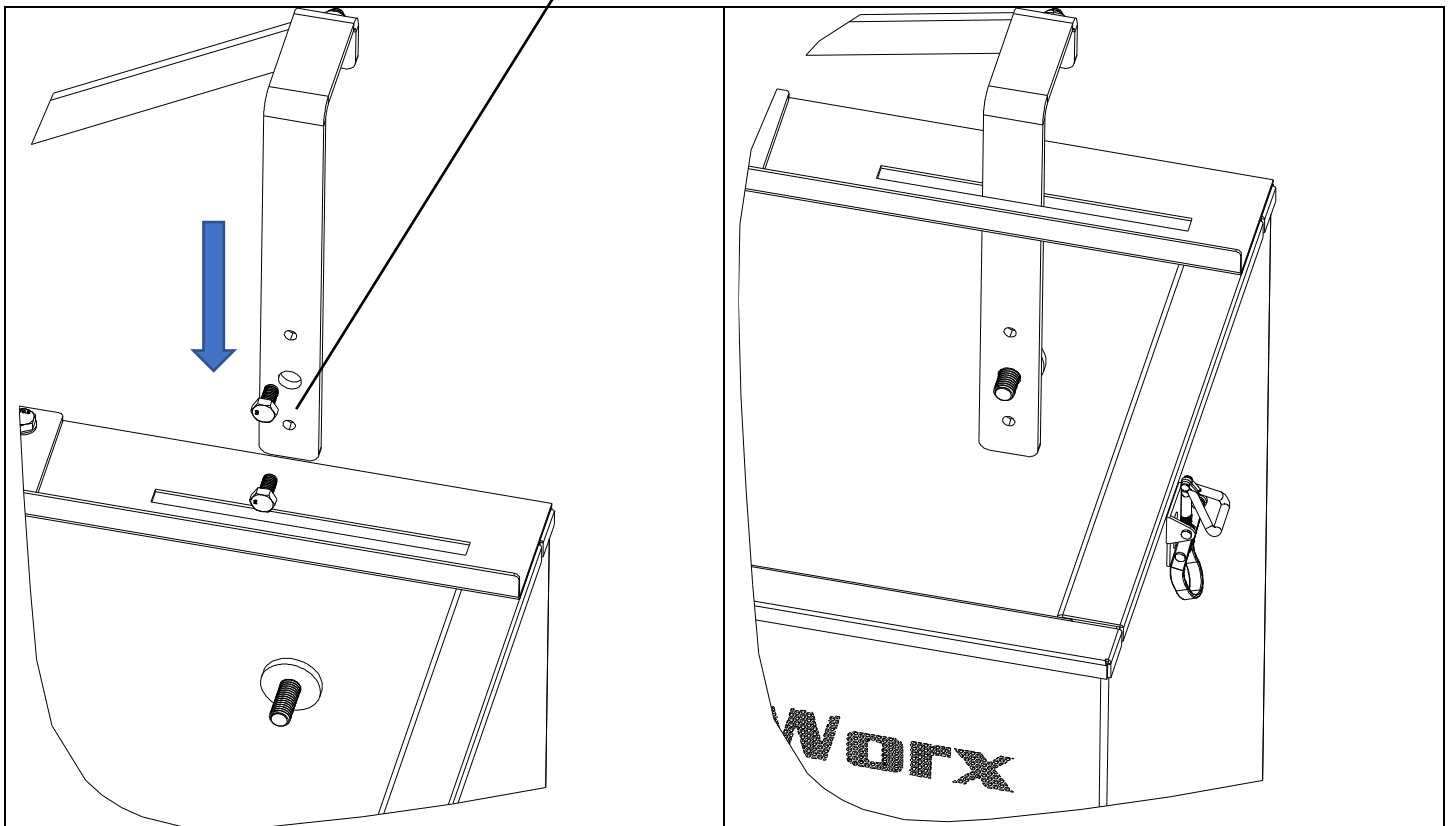

Remove the nut threaded on the stud and install the agitation sweep bar as shown, put it over the left stud first and then the right

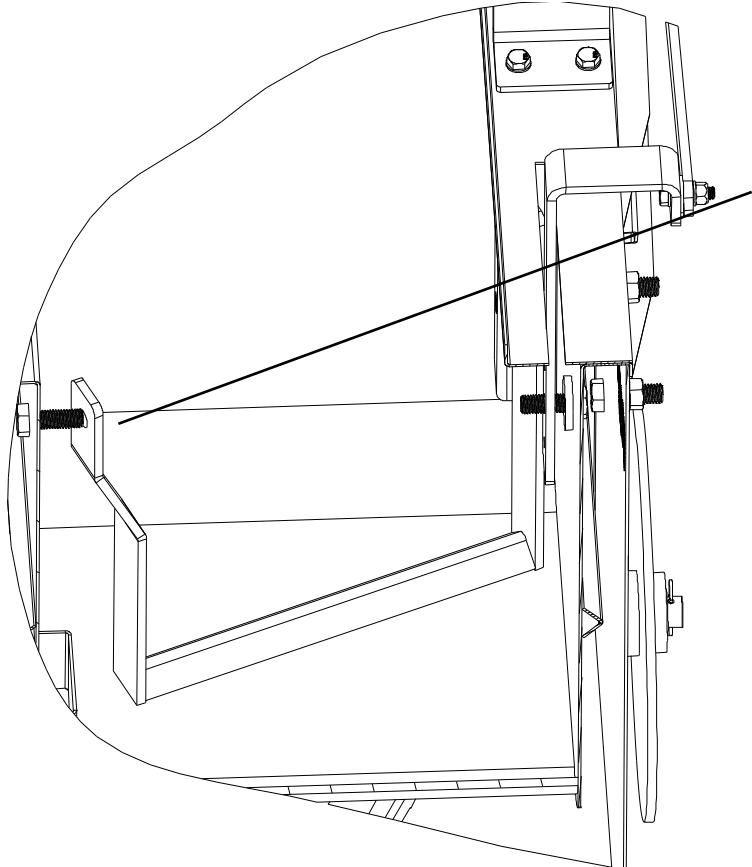

Attach the agitation sweep bar by reassembling the bolts to the agitation connector handle

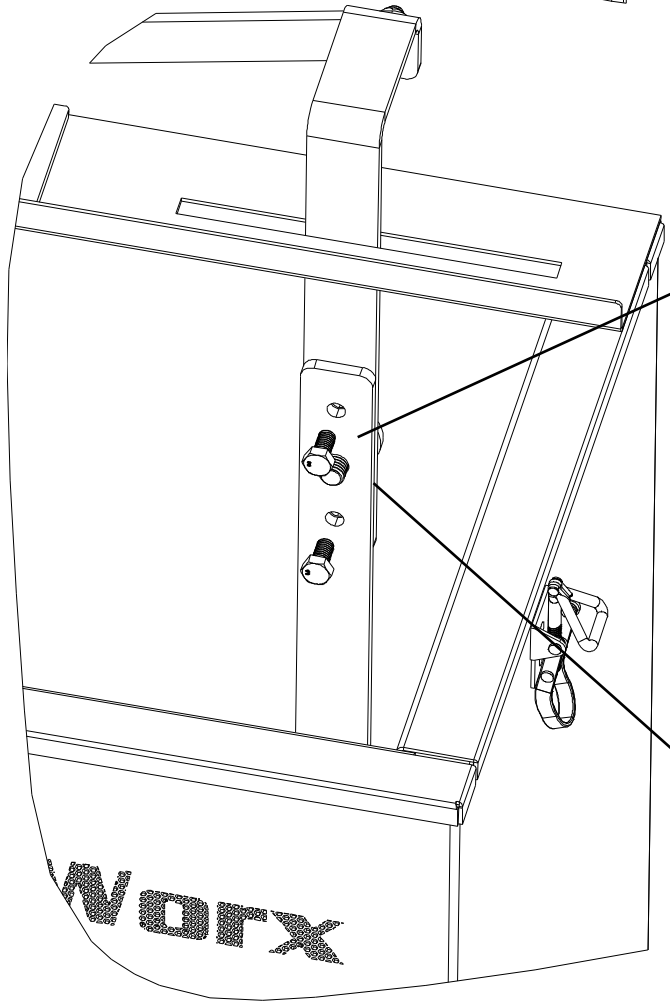

Note: No nut is installed on this side of the agitation bar.

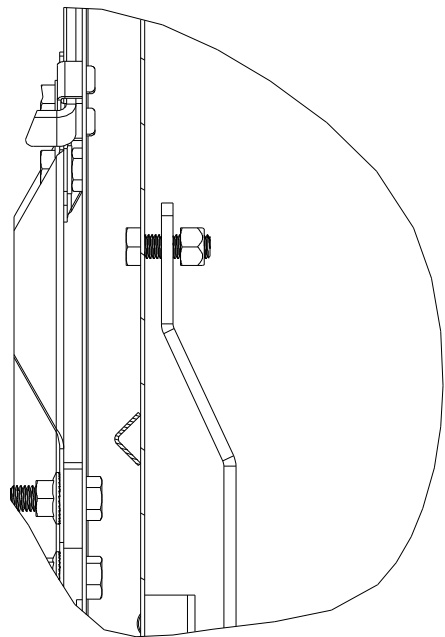
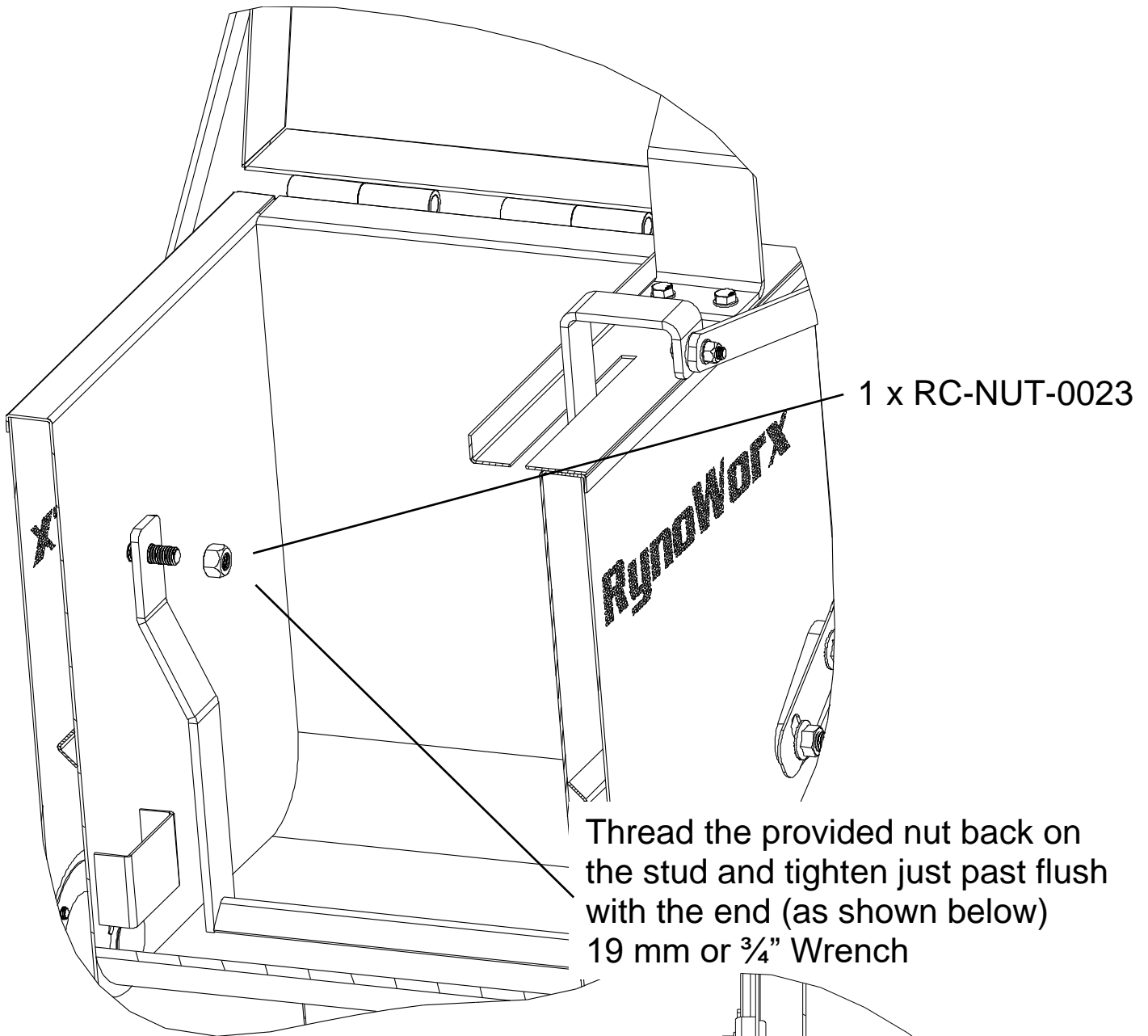

# 9. Lid Handle

RK-FAS-0070  
13 mm Wrench

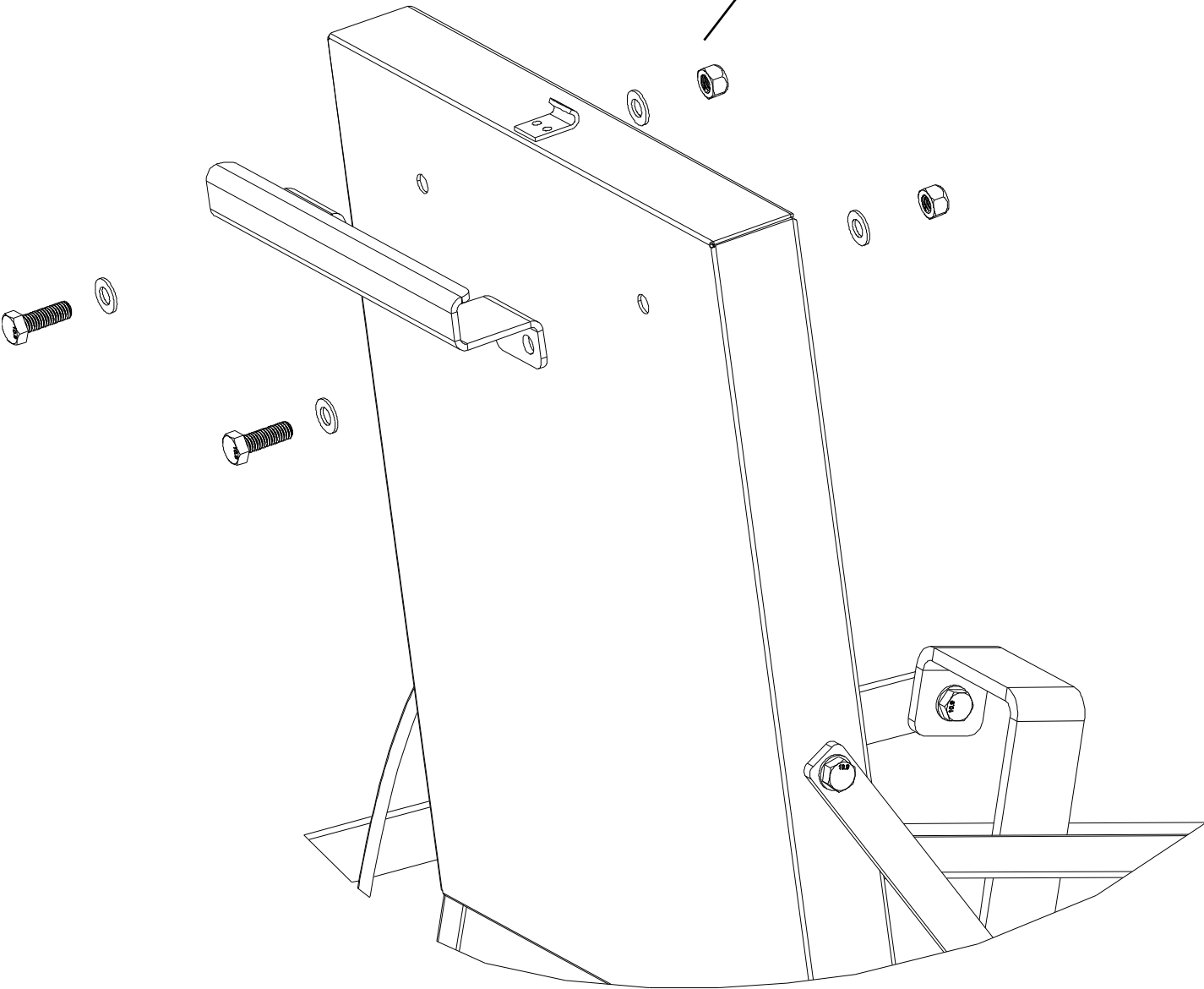

# 10. Accessory Torch

Connect the torch to the 30 psi adjustable regulator.

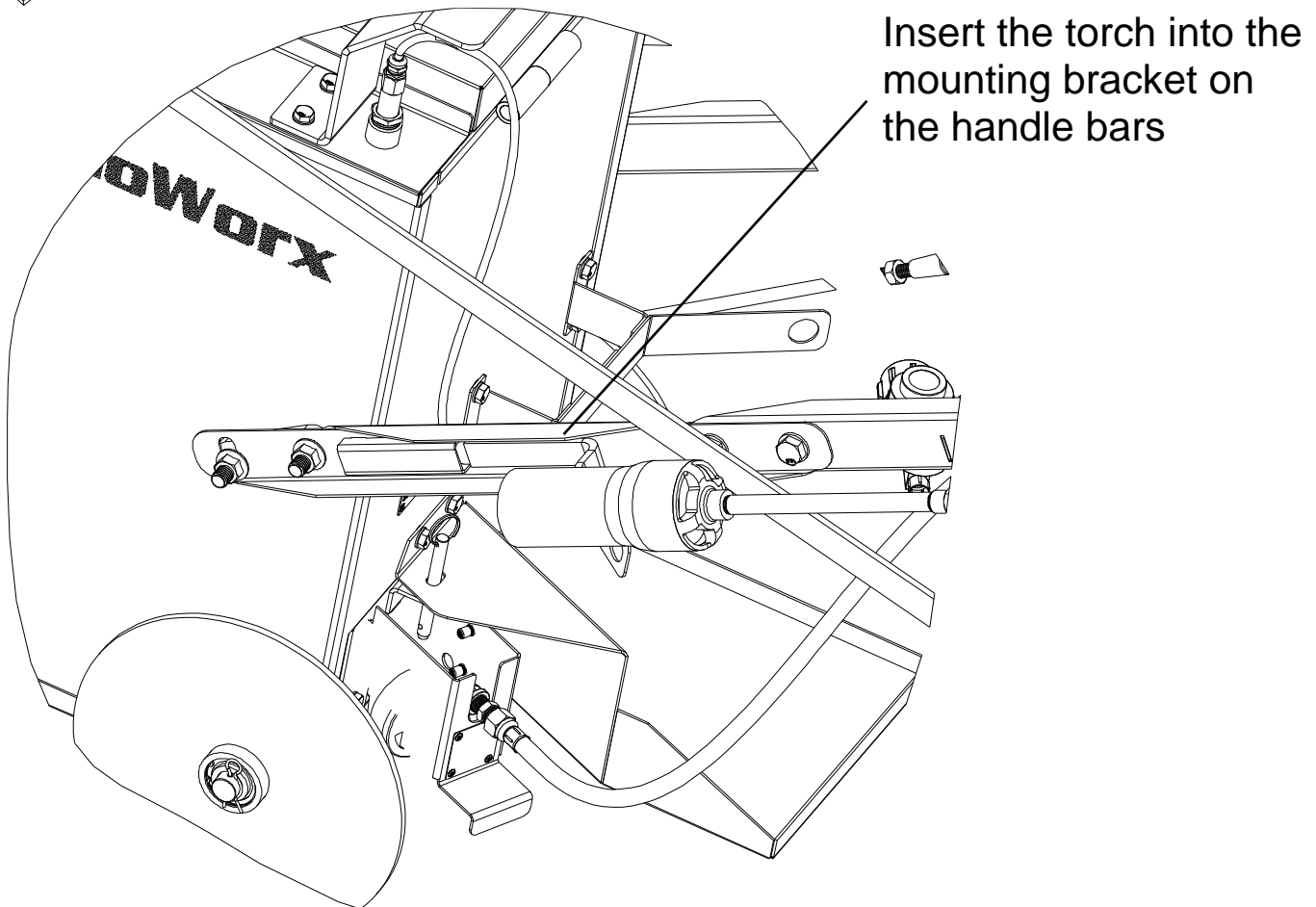
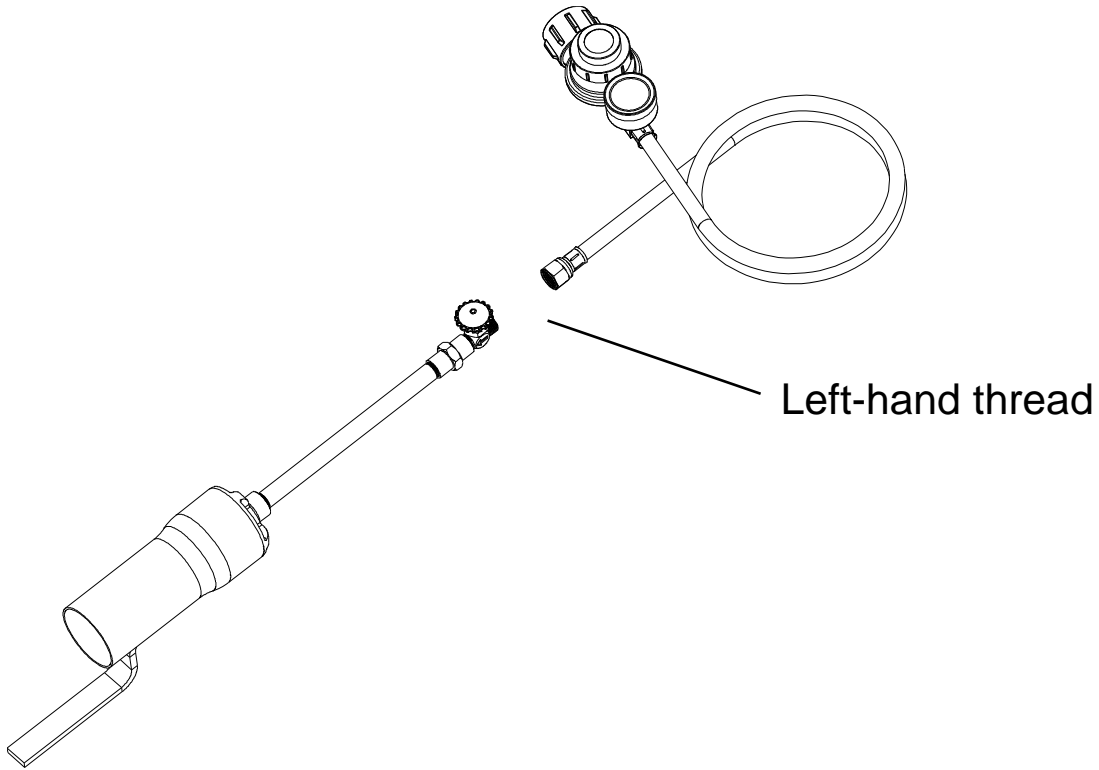



Hang the coiled torch hose on the holder bracket

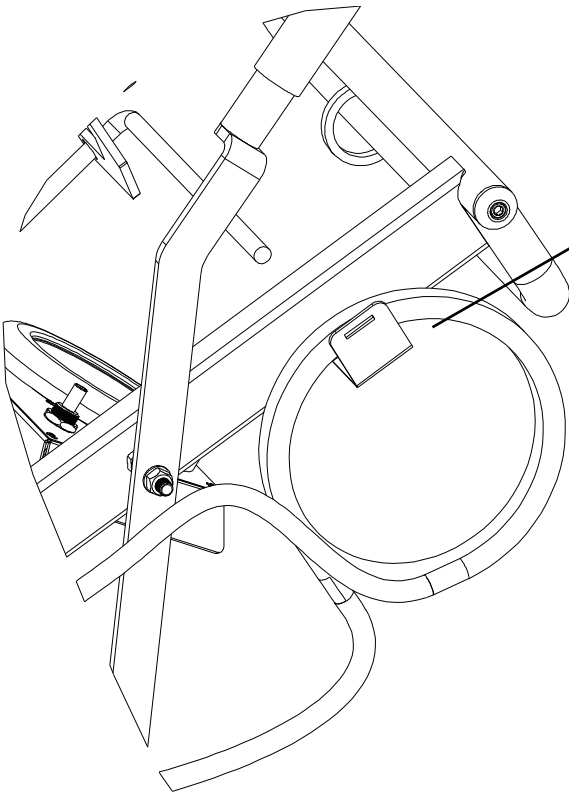

Connect the torch and burner regulators to the splitter.

30 psi torch regulator

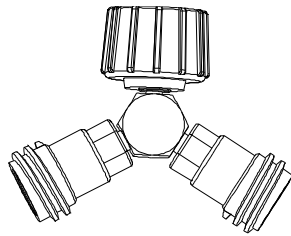
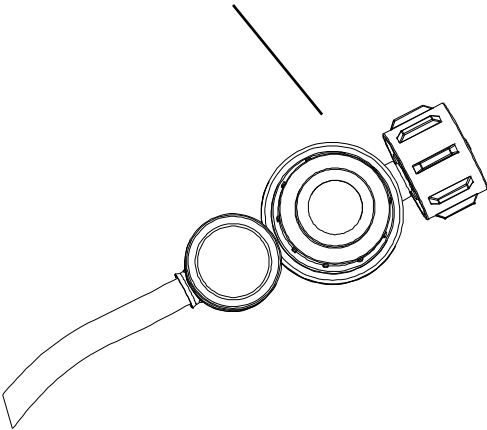

5 psi burner regulator

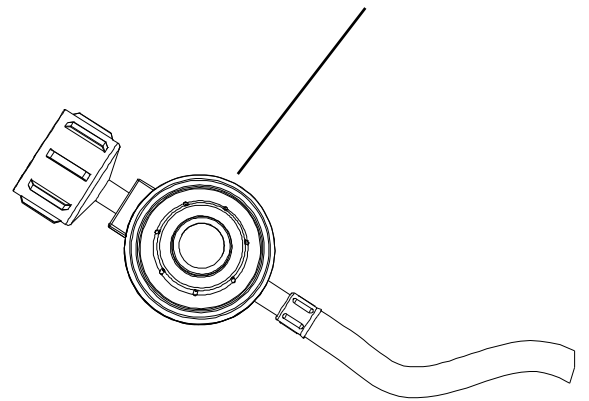

# 11. Shoe Control Arm

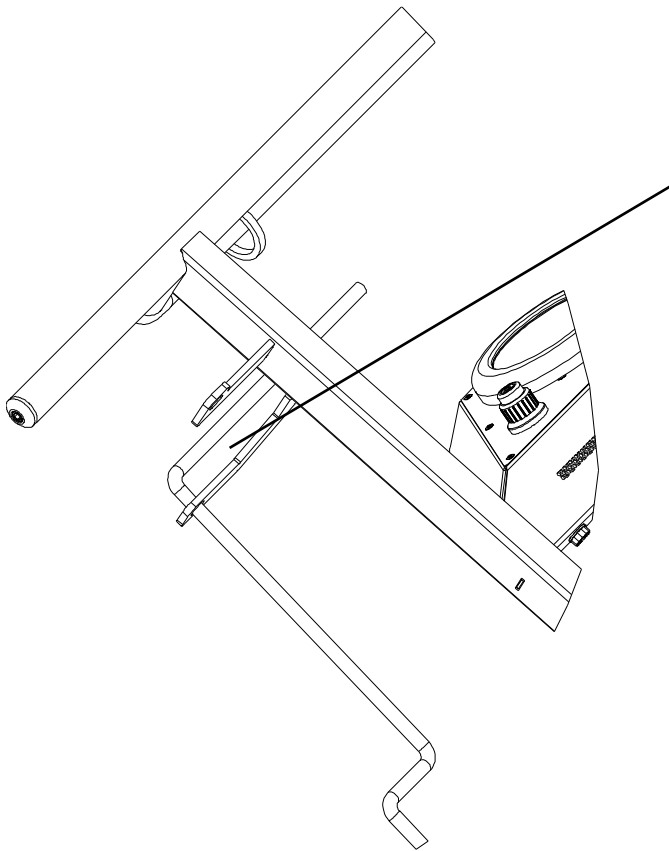

Insert the shoe control handle into the lower guide

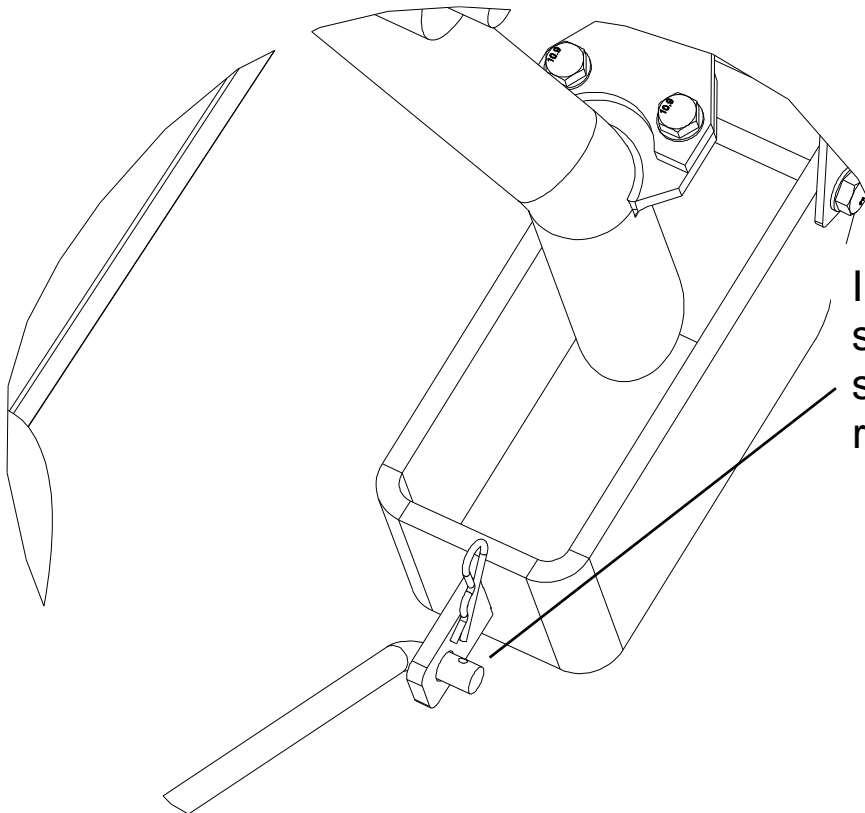

Insert the lower end of the shoe control rod into the shoe tab and insert the retaining pin.

## 12. Valve Control Arm

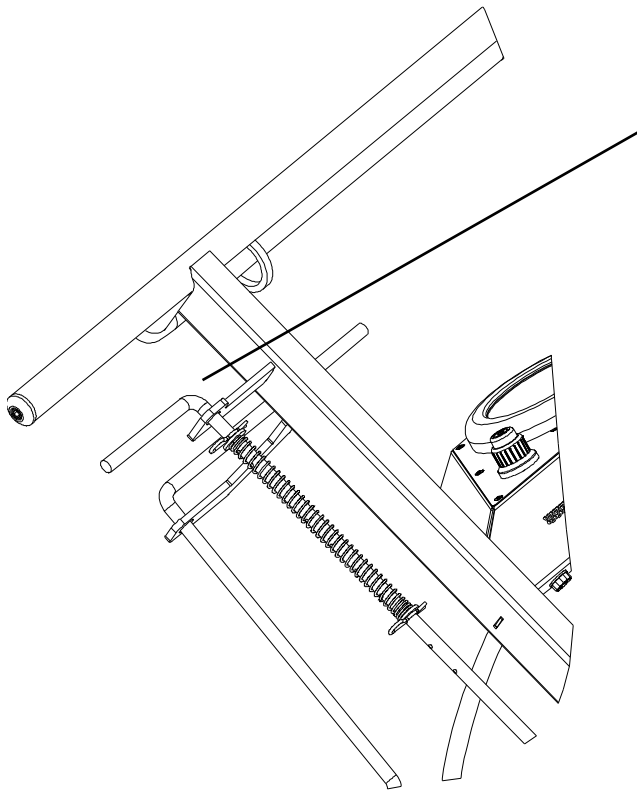

Insert the valve control handle into the upper guide

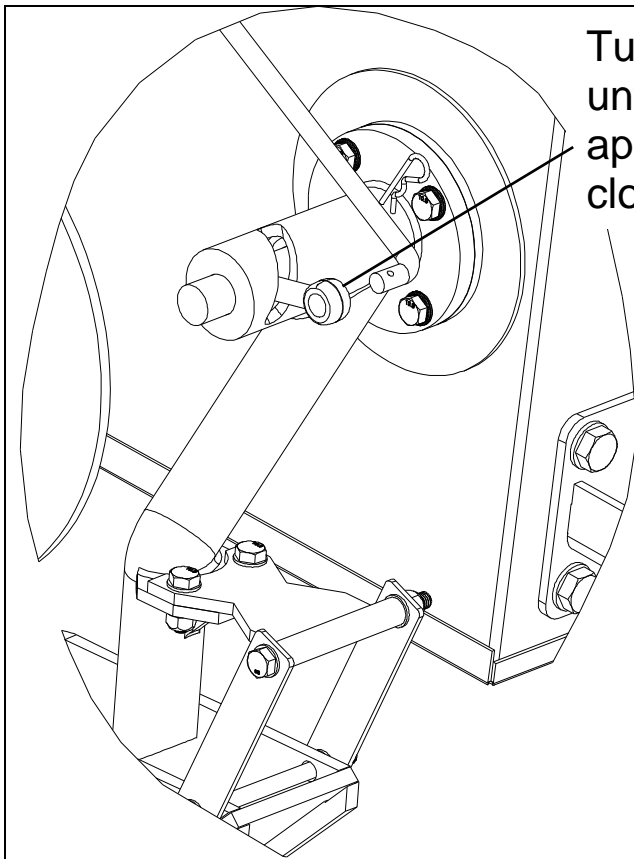

Turn the valve connector rod clockwise until it is tight and then turn it approximately 1 rotation counter-clockwise until its in the position shown

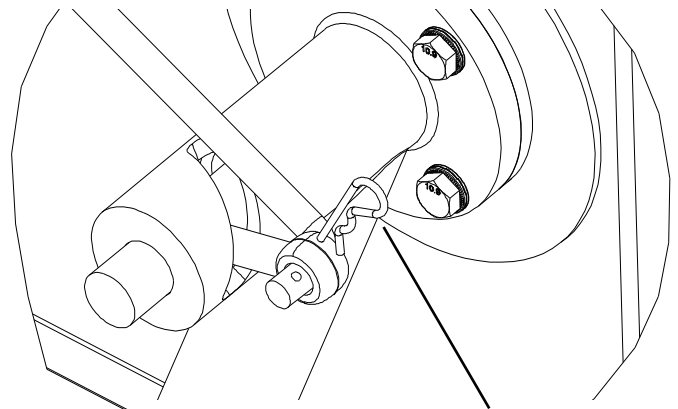

Insert the lower end of the control rod into the valve connector rod and insert the retaining pin.

# Set Up – Propane tank

Place your propane tank on the shelf and secure with the ratchet strap.

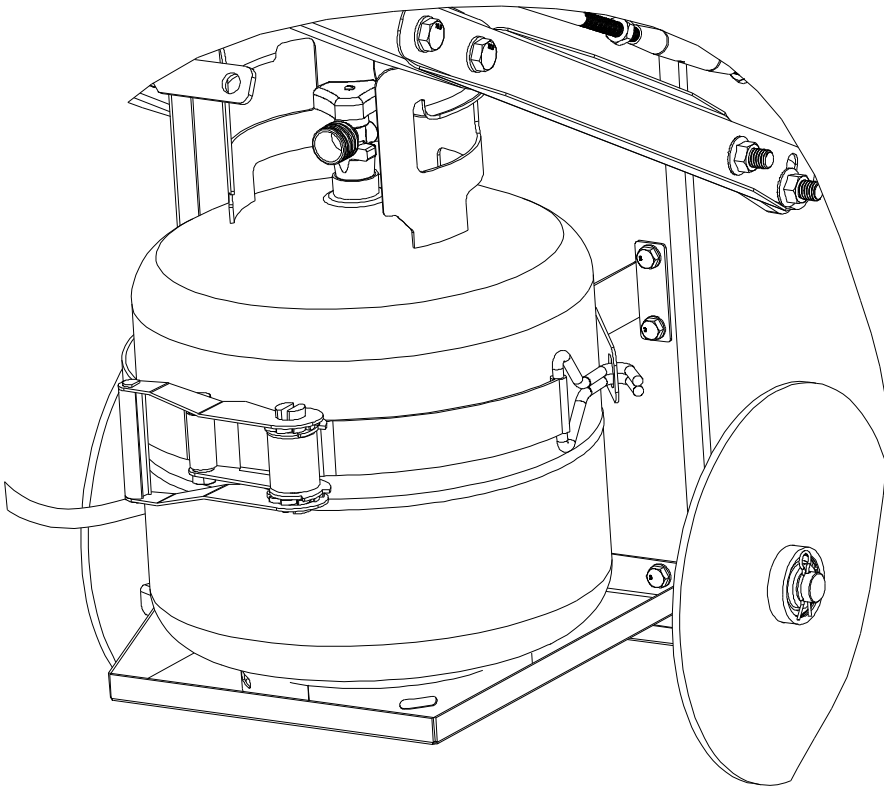

⚠ Only tighten the ratchet strap so that it is snug, do not apply excess force on the brackets

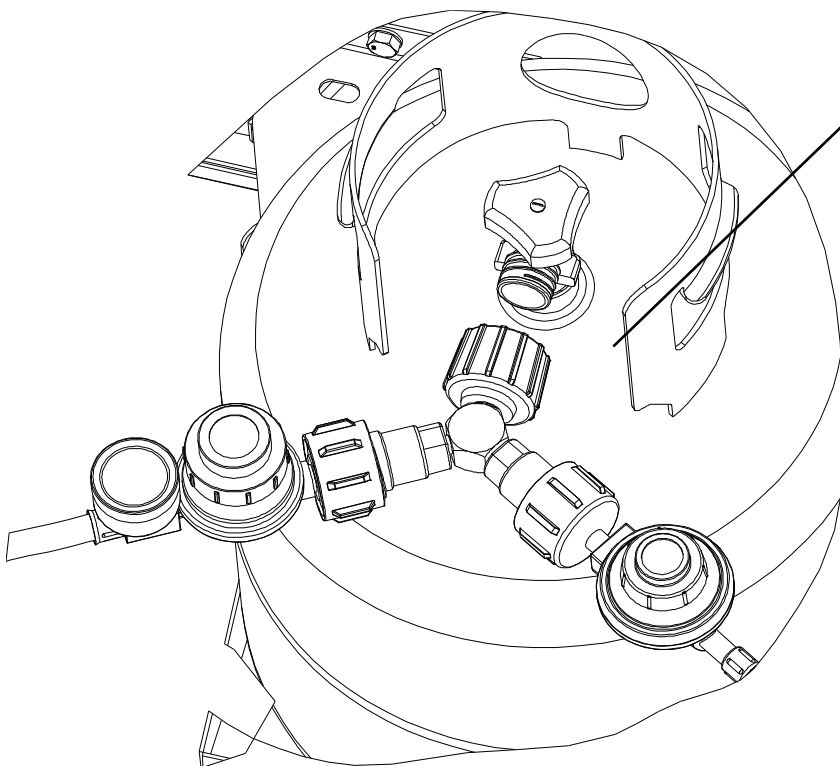

Connect the splitter to the propane tank

# Set Up – Handle Bars

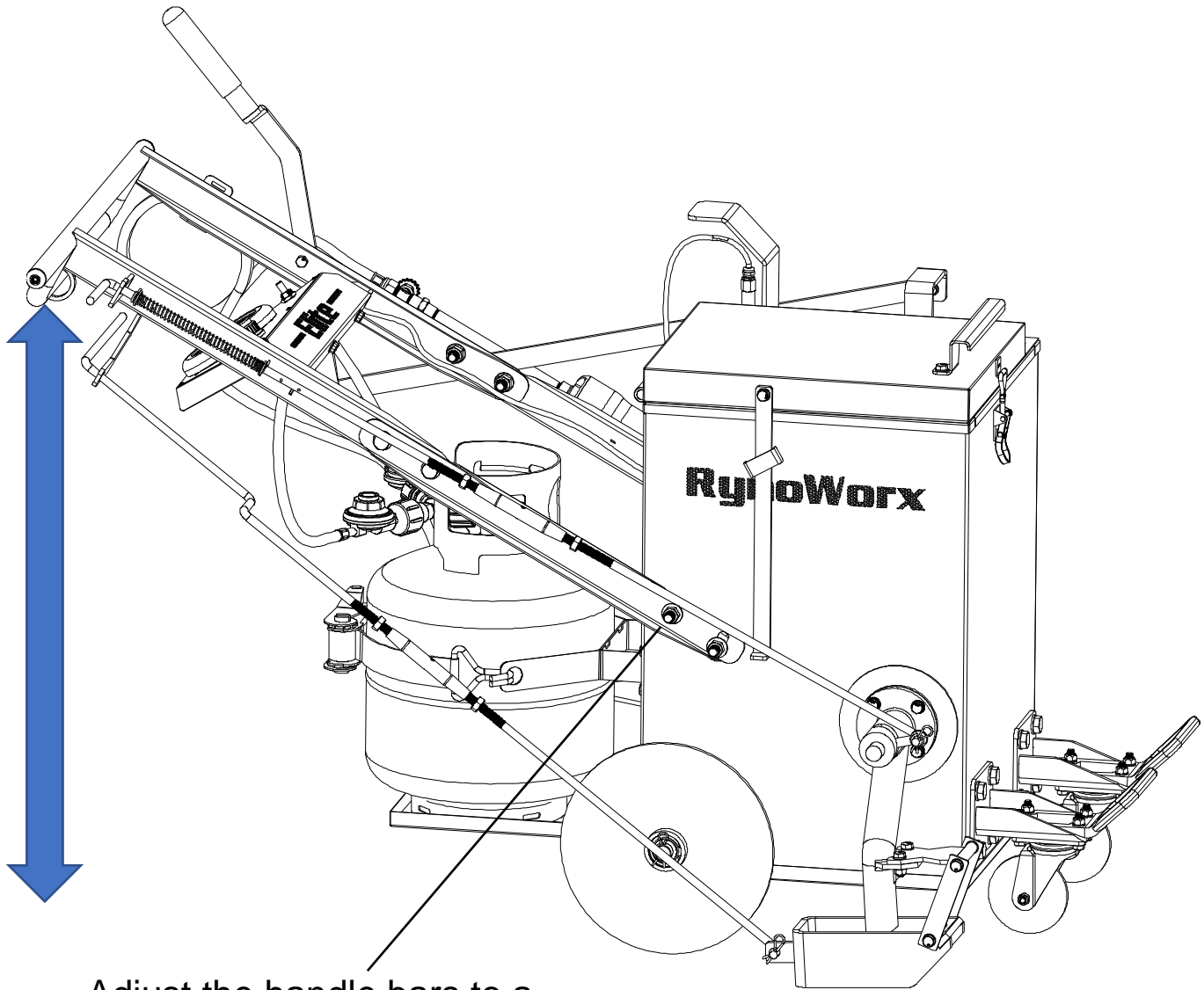

Adjust the handle bars to a comfortable height for the operator and tighten the flanged nuts on the studs (x2 each side)

# Set Up – Control Rods

⚠ Every time the handle bar height is adjusted the control rods need to be adjusted to the appropriate length so that they function properly.

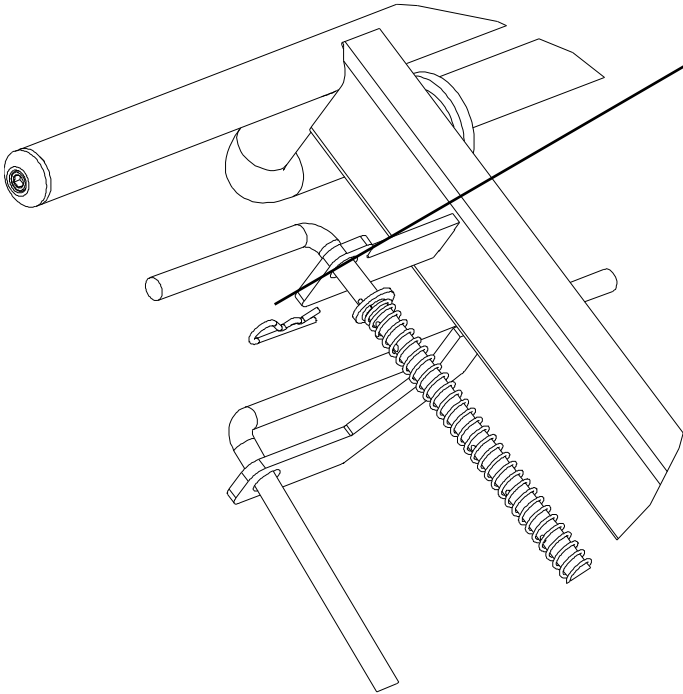

Remove the spring retainer pin to put tension on the valve control rod  
-This pin is just to hold the spring during shipping and can be discarded after installing the arm into the machine

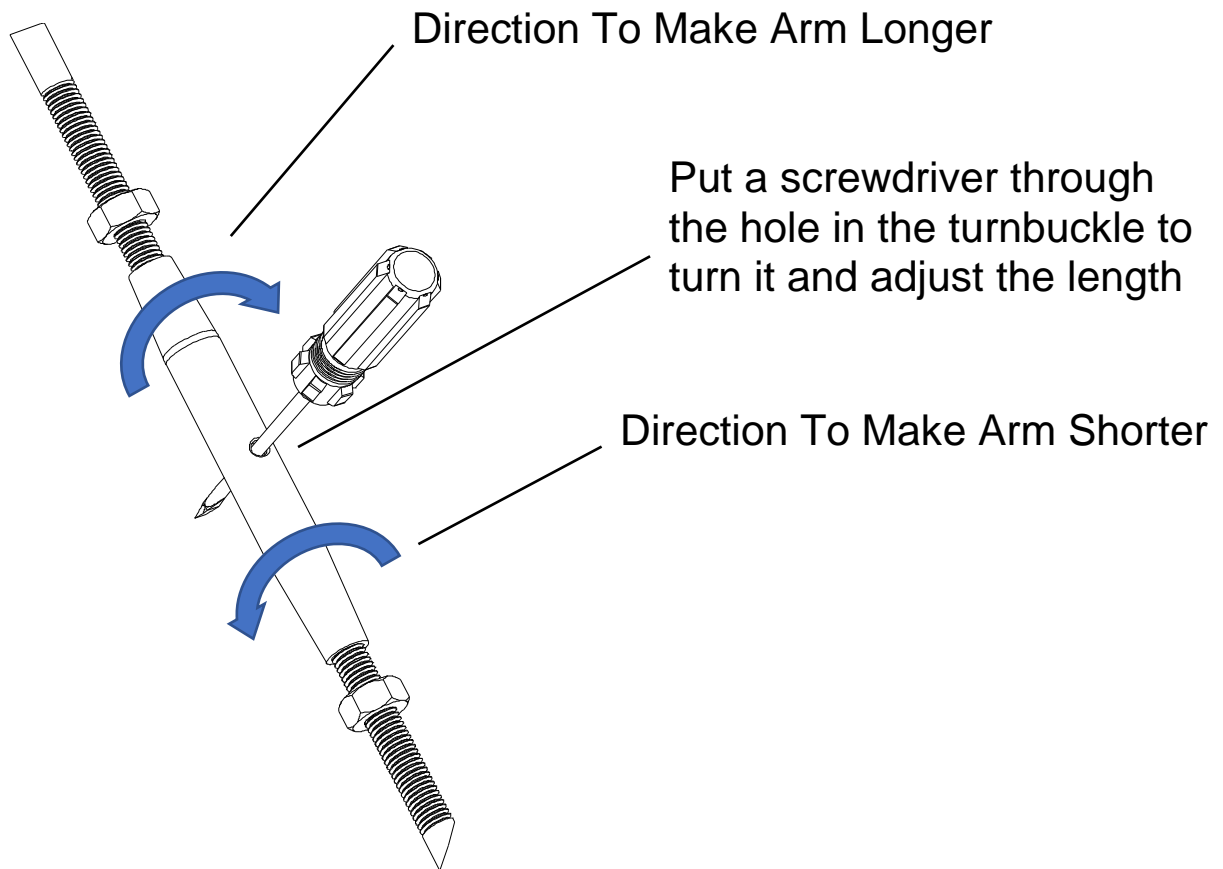

Direction To Make Arm Longer

Put a screwdriver through the hole in the turnbuckle to turn it and adjust the length

Direction To Make Arm Shorter

Adjust the length of the valve and shoe control rods so they are approximately in the position shown below.

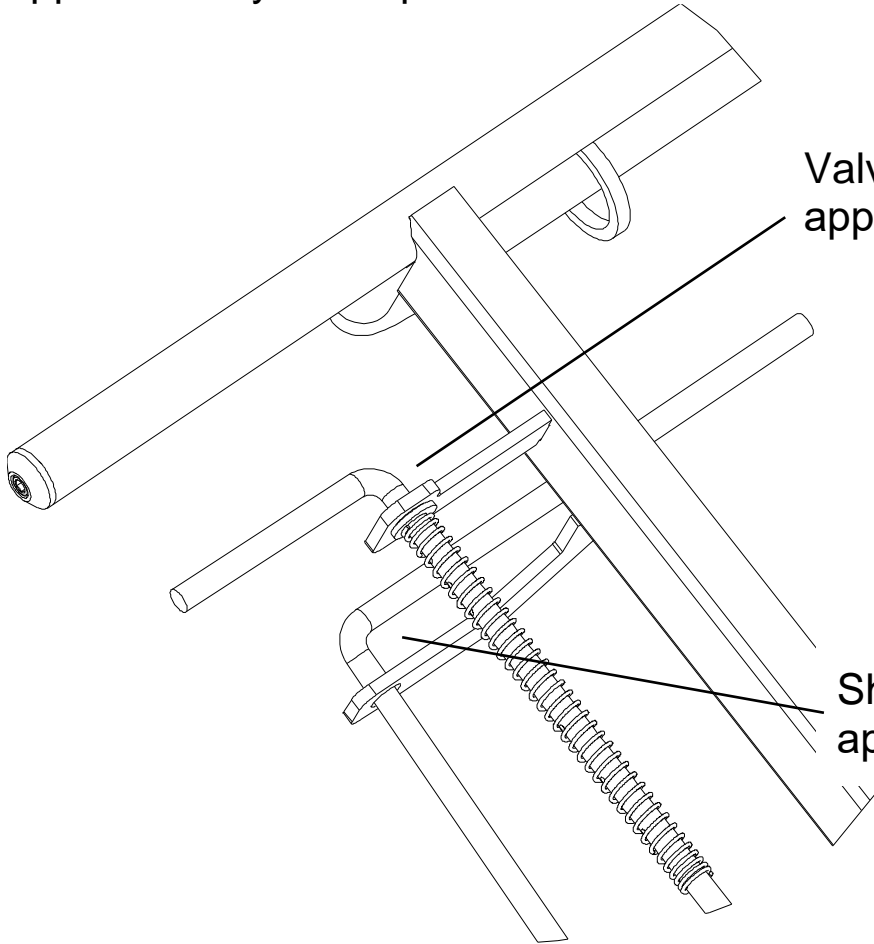

Valve control arm should be approximately 1/2" past the guide.

Shoe control arm should be approximately 1" past the guide.

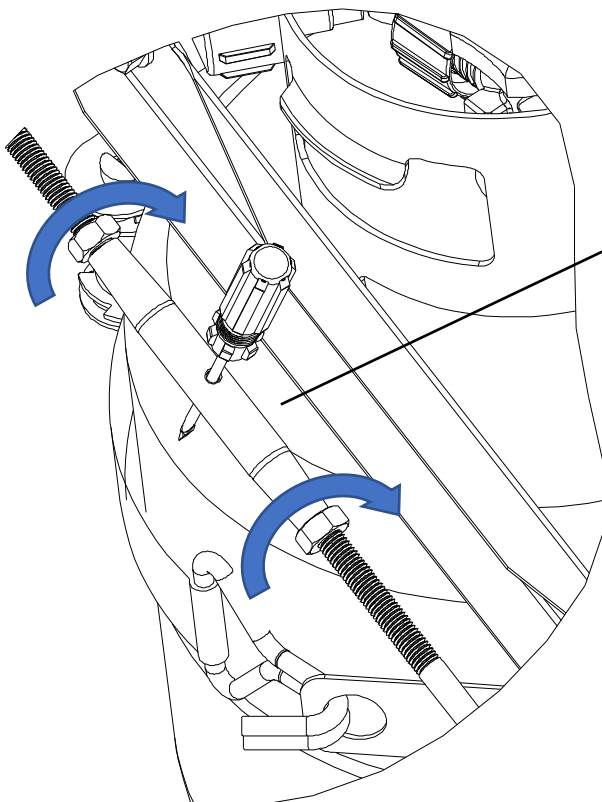

Once the control rod lengths are set, use a screwdriver to hold the turnbuckle in place and tighten the nuts against the turnbuckle

# Set Up – Adjust Spring Tension

The spring tension on the valve control arm can be adjusted by setting the pin position shown below which will increase or decrease the spring tension.

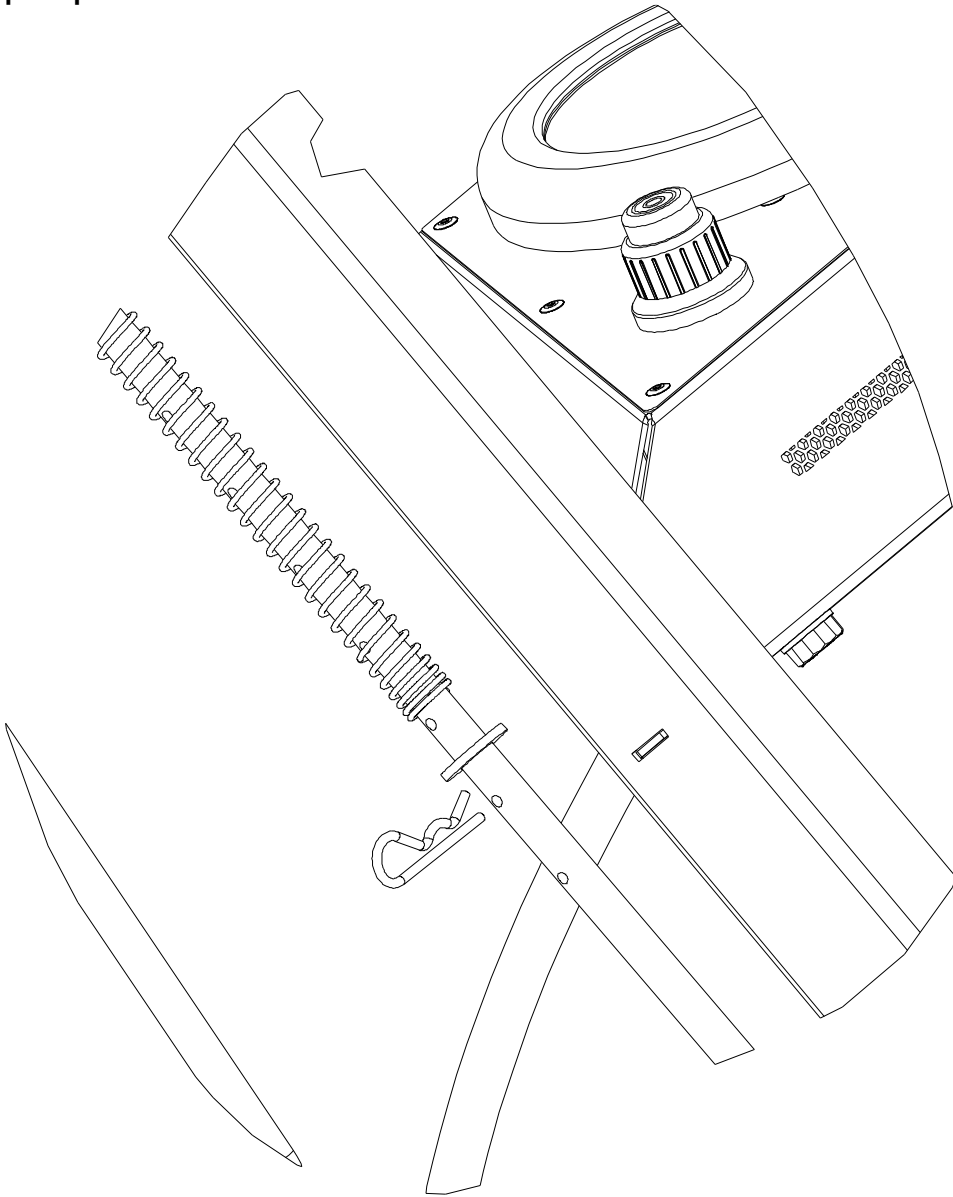



# Set Up – Installing Igniter Battery

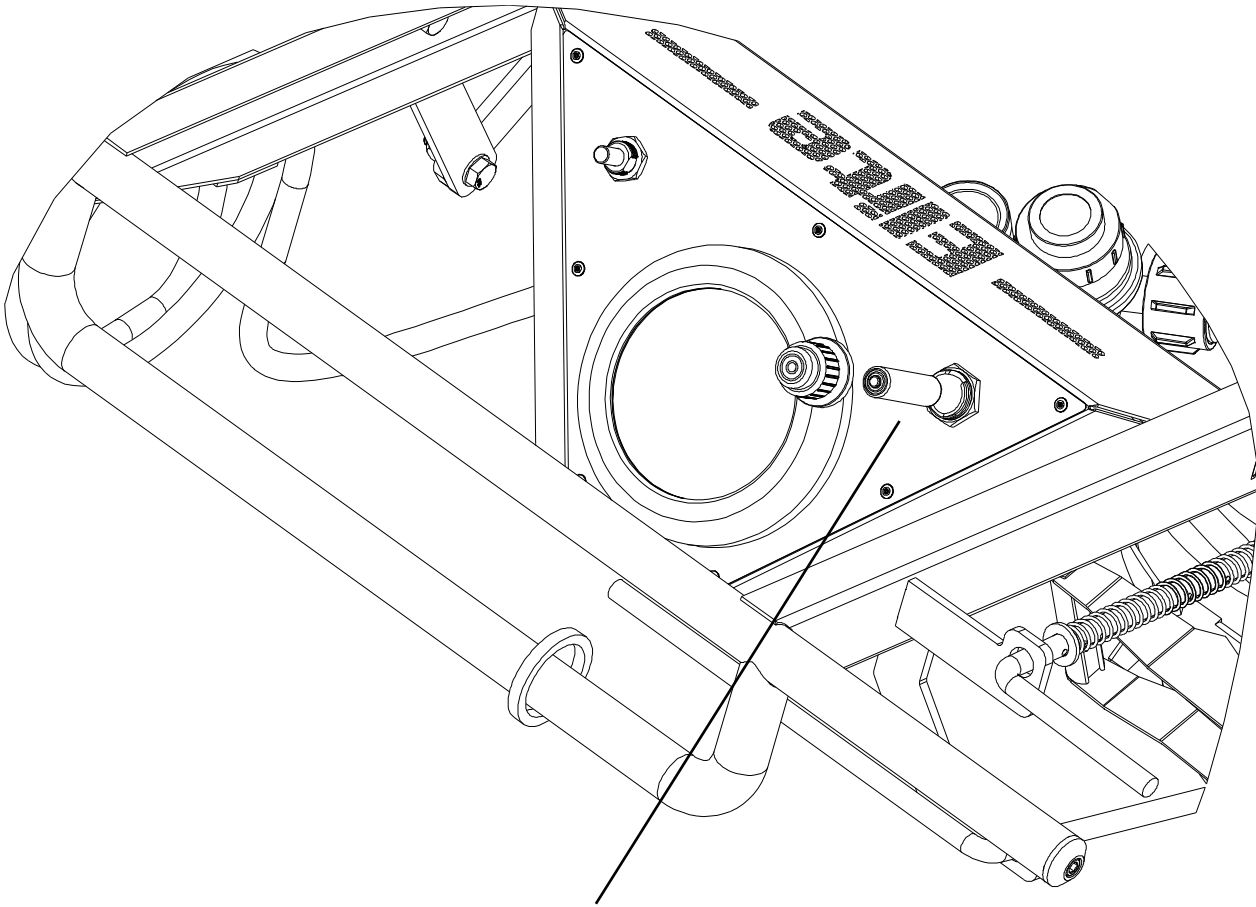

Unthread the igniter cap and insert the AA battery with the positive terminal facing up

- **Operations Guide**

---

Before beginning please check the following:

1. You have read and understand all warnings on page 2.
2. You are using a new and full propane cylinder (use of a used cylinder can lead to reduced performance or equipment failure).
3. You have inspected your regulator, hose, and burner assembly and verified there are no leaks or physical damage.
4. You are outdoors in a well ventilated area that is free and clear of any flammable matter.
5. You have completed the assembly of the equipment correctly.
6. You have 'Direct Fire' type crack sealant such as GemSeal, SealMaster, Durafill, Craftco, or Maxwell.
7. There is absolutely NO water in or around the kettle.
8. You are wearing protective eyewear.
9. You are wearing heat and fire resistant protective gloves.
10. You are wearing heat and fire resistant protective clothing which covers all exposed skin.

- **Operation Guide**

---

### **Part 1 – How to Load and Light your Melter**

1. Ensure your regulator is off by rotating regulator knob fully counter-clockwise (rotate left).
2. Slowly pressurize the regulator by rotating the valve located on the propane cylinder counter-clockwise all the way (rotate left).
3. Inspect and ensure there are no leaks between any of the connections before proceeding.
4. Load crack sealant into kettle, while ensuring sealant is resting on the bottom of the kettle.
5. Pressurize the propane hose by rotating the regulator knob fully clockwise (rotate right).
6. Press and hold the electric igniter button immediately followed by the burner starter button. Continue holding both buttons until the burner ignites.
7. Once the burner ignites, release the electric igniter button, however continue to hold the starter button for an additional 15-20 seconds. This will eventually deactivate the flame-out sensor which is responsible for ensuring the burner stays lit.
8. Once lit, you can control the temperature by adjusting the regulator.



⚠ Operating the burner on high in most conditions is not recommended, this can harm sensitive electronic components and dangerously overheat fuel carrying lines.

⚠ Never exceed the manufacturer's recommended material maximum temperature.

- **Operation Guide**

---

### **Part 2 – Agitating and Monitoring Temperature**

1. Never leave melter unattended when the burner is lit. If flame goes out, promptly turn off the flow of gas; double check that the melter is free and clear of any gas odors before attempting to re-ignite the burner.
  2. While your melter is ignited you should continuously be monitoring the material temperature. Check with crack sealant manufacture for safe melting temperatures and ensure you continually adjust your regulator to maintain the recommended temperature range. If the material becomes too hot, you may need to turn off your burner periodically.
  3. As material begins to melt, it's important to consistently agitate. Agitation moves the solid crack sealant along the bottom and prevents 'hot spots' from forming which can alter the effectiveness of the sealant after applied. Agitation also prevents chunks of over-heated material from forming which will eventually plug or block your flow valve which can slow down the applications process.
- 

### **Part 3 – Dispensing Crack Filler**

Once you have effectively liquefied the crack sealant, you may begin applying it. For best results, the surface should be clean and free of dirt, debris and vegetation. Ensure shoe is lowered and resting on the pavement. Push melter into position, aligning the crack you wish to fill with the center of the shoe. Slowly squeeze the valve control arm until crack filler begins to come out of the valve and onto the crack. Slowly push the melter forward, keeping the crack aligned with the center of the shoe. Increase speed of the material flow by squeezing harder on the valve control arm. If material flow slows, check to ensure that you have enough melted material in the kettle and agitate to keep the flow tube clear.

---

### **Part 4 – Turning Off and Draining**

Once you have finished using the melter, make sure it is fully drained and no crack filler remains inside the kettle or the flow valve. Leaving the flow valve empty after use will prevent the valve from being blocked the next time you use the melter.

---

- **Operation Guide**

---

## **HOW TO – Thermocouple Bypass (Emergency use only)**

**\*\*\*USE OF THIS BYPASS IS AT YOUR OWN RISK\*\*\***

On occasion, you may run into a situation where your flame out valve is preventing you from completing your job. This may be due to a damaged thermocouple, or the flame-out valve itself.

The new flame-out bypass (RC-CAP-0008) is designed to allow you to finish your job, while you wait for replacement parts. The Bypass is designed for temporary, emergency use only, and should be removed immediately upon work completion.

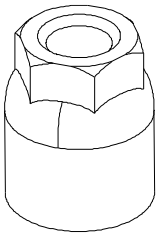

The cap is designed to screw onto the top of the flame-out valve.

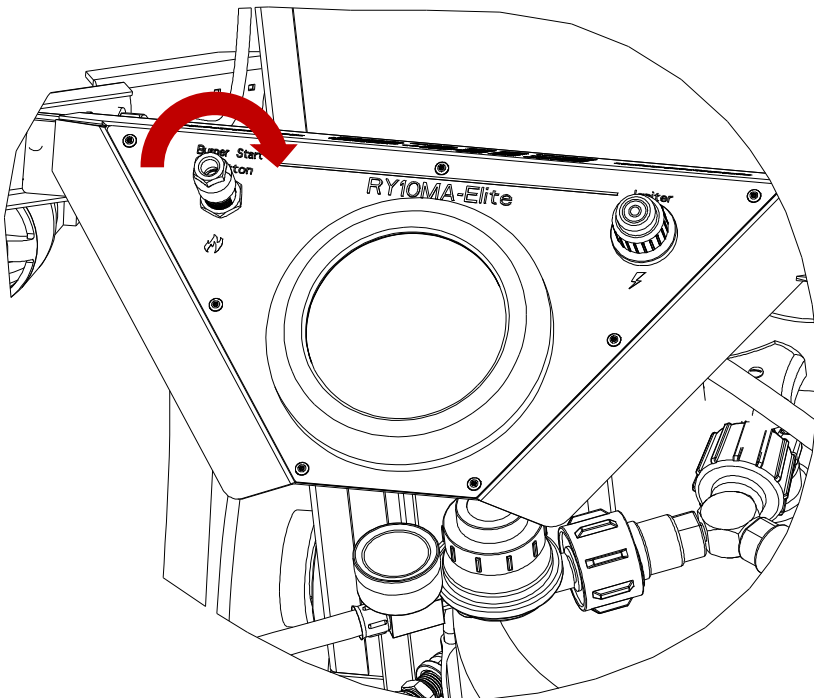

Simply thread the cap with your fingers over the button on the flame-out valve until snug.

**\*\*\*NEVER LEAVE THE EQUIPMENT UNATTENDED WHILE INSTALLED\*\*\***

- **Maintenance Guide**

---

### Periodic Maintenance

This melter / applicator requires periodic maintenance before each use and at set intervals in order to ensure it is performing safely and optimally. The table below describes checks and maintenance which are recommended.

Description	Before Each Use	Every 25 Hours	Every 75 Hours
Check Propane Tank fuel level, refill as needed	X		
Inspect regulator and hose for physical damage or leaks	X		
Inspect front caster wheel, apply grease and tighten fasteners as required	X		
Inspect thermometer for physical damage or malfunctions	X		
Heat up the valve with a heating torch to remove any residual material build up		X	
Remove and thoroughly clean control valve			X

• **Troubleshooting Guide**

---

Below we have provided a common problems and solutions table. Be sure to consult this table should you experience any technical problems.

Description of Problem	Possible Causes	Known Solutions
The burner will not ignite or the burner will not stay lit	1) The electric ignition may have dead or low power batteries 2) Starter button not being held long enough for ignition to take place 3) The fuel level could be too low 4) The propane cylinder valve could be partially or fully closed, which can restrict fuel flow 5) The pressure regulator valve may be in the off position or may not be providing sufficient fuel flow	1) Change the batteries located in the ignitor assembly, double check spark. 2) Ensure you hold your starter button until the burner ignites, continue to hold for an additional 15-20 seconds 3) Check and refill your fuel tank 4) Ensure your fuel valve is fully open, you can do this by turning the knob fully counter-clockwise 5) You may increase the pressure from the regulator by turning the knob clockwise
Burner will not stay lit	1) The fuel level may be too low 2) Loose connection between the thermocouple and flame-out valve	1) Refill your fuel tank 2) Tighten the thermocouple connection to the flame-out valve
Crack filler is melting really slowly	1) Incorrect crack sealant being used 2) Burner is not providing enough heat to melt the crack sealant 3) The temperature outside is cooler than normal slowing down the melting process	1) Double check that your using an approved crack sealant for use in direct-fire melters 2) Increase the fuel to your burner 3) No solutions, melting takes longer on cooler days