

Ryno Worx

Operator's Manual

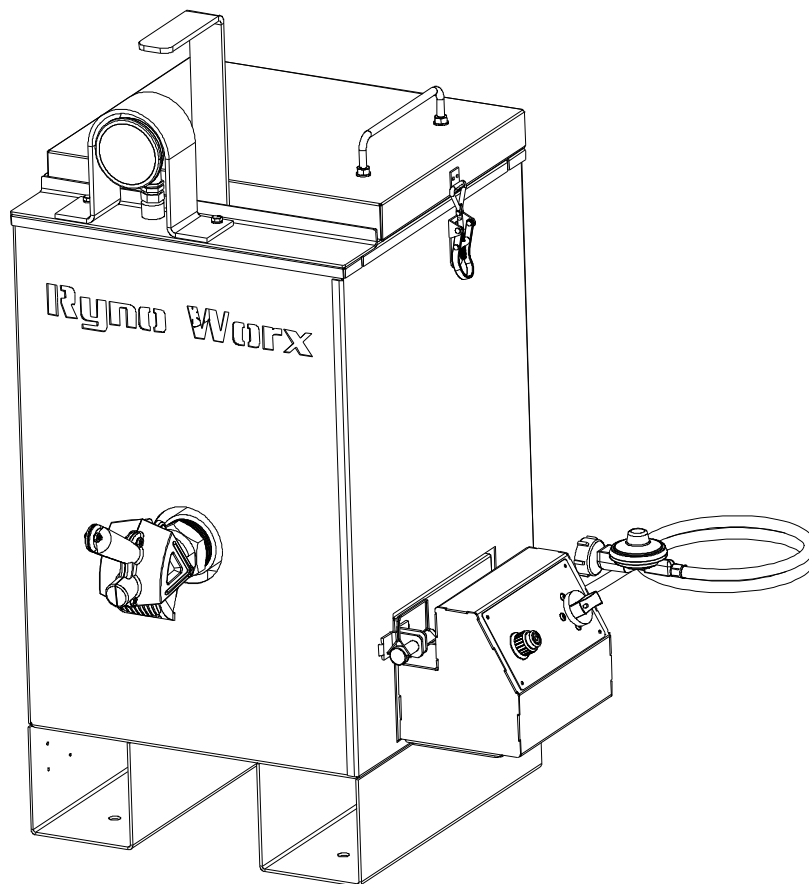

Model: RY10MK-PRO

MPN: RA-MLT-0009

10 Gallon Direct Fire Melter Kettle
Burner Model with Adjustable Flame-Out Valve

U.S. Patent No. 9,739,021

For Technical Support Please Visit www.RynoWorx.com or Call 1-855-382-9611

WARNING

- ⚠ Read all instructions and warnings in this manual before attempting to operate this equipment.
- ⚠ This equipment is designed for outdoor use only.
- ⚠ This equipment gets hot during normal operation, do not mount this equipment on or near any combustible surfaces.
- ⚠ Be sure to always wear personal protective equipment when operating this equipment.
- ⚠ Improper assembly may be dangerous. Please follow the assembly instructions in this manual. Make sure all parts are assembled and hardware is fully tightened before using. Make sure that there are no leaks in the liquid propane cylinder connection or lines.
- ⚠ Do not operate this equipment if a gas leak is present.
- ⚠ Do not operate this equipment while mounted on a moving vehicle.
- ⚠ Do not store spare liquid propane cylinders within 10 feet (3m) of this equipment.
- ⚠ Inspect the gas lines and connections before every use. Do not use this equipment if these components are damaged or worn.
- ⚠ Do not attempt to disconnect the gas regulator from the tank or any gas fitting while the equipment is in use.
- ⚠ A dented or rusty liquid propane tank may be hazardous and should be checked by your liquid propane supplier. Do not use a liquid propane tank with a damaged valve.
- ⚠ Before servicing, make sure the unit is fully cooled and the liquid propane cylinder is disconnected.
- ⚠ Only genuine Ryno Worx replacement parts should be used for any replacements or repairs. Do not attempt to modify or alter this product in any way.
- ⚠ Keep a fire extinguisher approved for oil fires on hand when using this equipment. If flashing occurs NEVER use water to put out the fire.
- ⚠ Do not attempt to make any repairs to gas carrying, gas burning, igniter components or structural components. Your actions, if you fail to follow this warning, may cause a fire, an explosion, or structural failure resulting in serious personal injury or death as well as damage to property.
- ⚠ This equipment should only be used with "Direct Fire" hot melt crack sealant. Consult the directions provided by the crack sealant manufacturer and never exceed their recommended heating temperature.
- ⚠ Failure to follow these instructions could result in fire or explosion which could cause property damage, personal injury or death.

• Parts List

No.	Description	P/N
1	2" NPT Molasses Valve Assembly	RA-VLV-0003
2	Thermometer - Shock Proof Glycerin Filled	RC-GCM-0010
3	Burner Tray Complete Assembly - Kettle Jet Burner	RA-BAS-0043

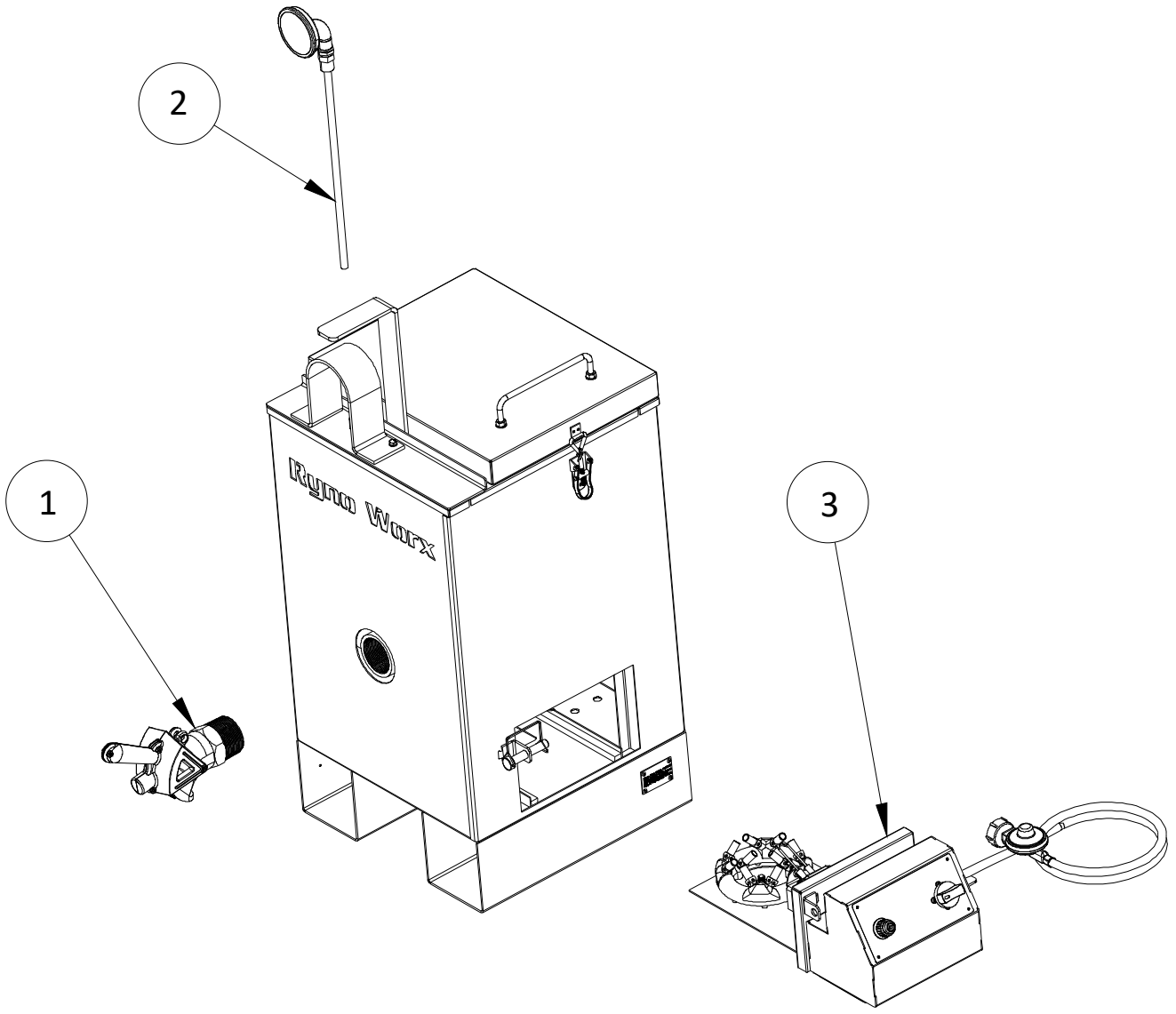

• **Parts List**

No.	Description	P/N
1	Zinc Alloy Knob H-07	RC-GCM-0055
2	Electronic Ignitor Switch Assembly	RA-GCM-0005
3	Low Pressure Flame Out Valve - 3/8" Male Flare Fittings	RA-VLV-0014
4	Thermocouple - M8x1mm Thread	RC-GCM-0052
5	Double Ignition with 2 Wires	RC-GCM-0054
6	Jet Burner Assembly	RA-BRN-0004
7	Brass Jet	RC-FAB-0077
8	Low Pressure Propane Regulator with 6' Hose	RC-GCM-0053

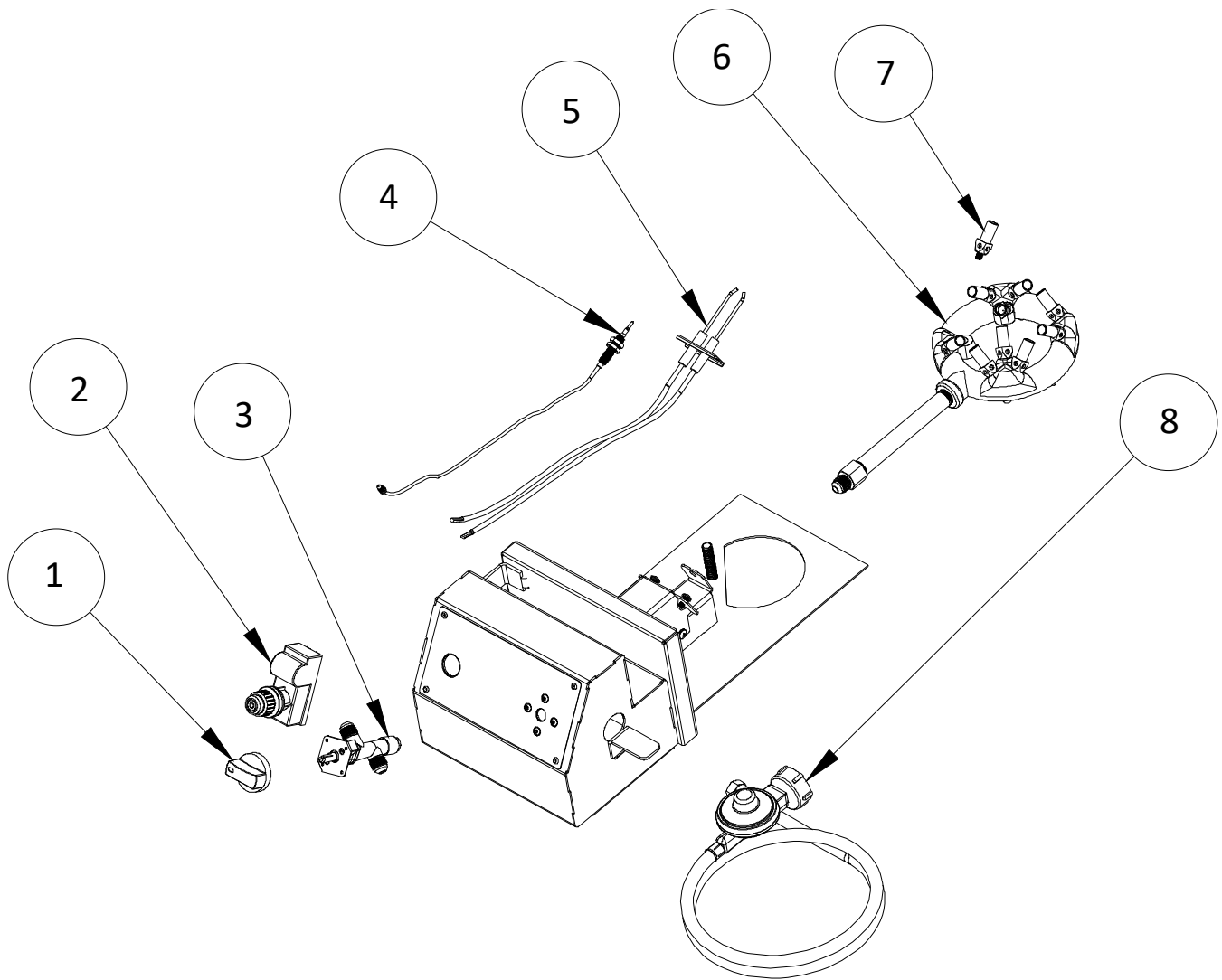

- **Introduction**

Forward

Thank you very much for purchasing Ryno Worx crack maintenance equipment. We pride ourselves in being different from other equipment manufacturers with a relentless focus on innovation, simplicity, and quality.

This melter was designed to be used with 'Direct Fire' crack sealants only. Please be sure to purchase the correct material to ensure safe and effective operation.

Within this document are complete instructions for how to assemble, use and care for your equipment. Please make sure you read and follow all instructions provided.

Within this document you will find the following resources:

- **Assembly Instructions** – These instructions will assist you in assembling and preparing your melter for first time use.
- **Operation Guide** – This guide will explain the functions and controls of the melter and how to use them.
- **Maintenance Guide** – This guide will provide you with suggested maintenance tips and techniques to ensure proper function and optimal performance.
- **Troubleshooting Guide** – This guide will provide you with the most commonly reported problems, possible causes, and known solutions.

1) Install the Agitation Bar

Position the short side of the agitation bar over the right mounting stud first and then carefully bend the long side over the left stud

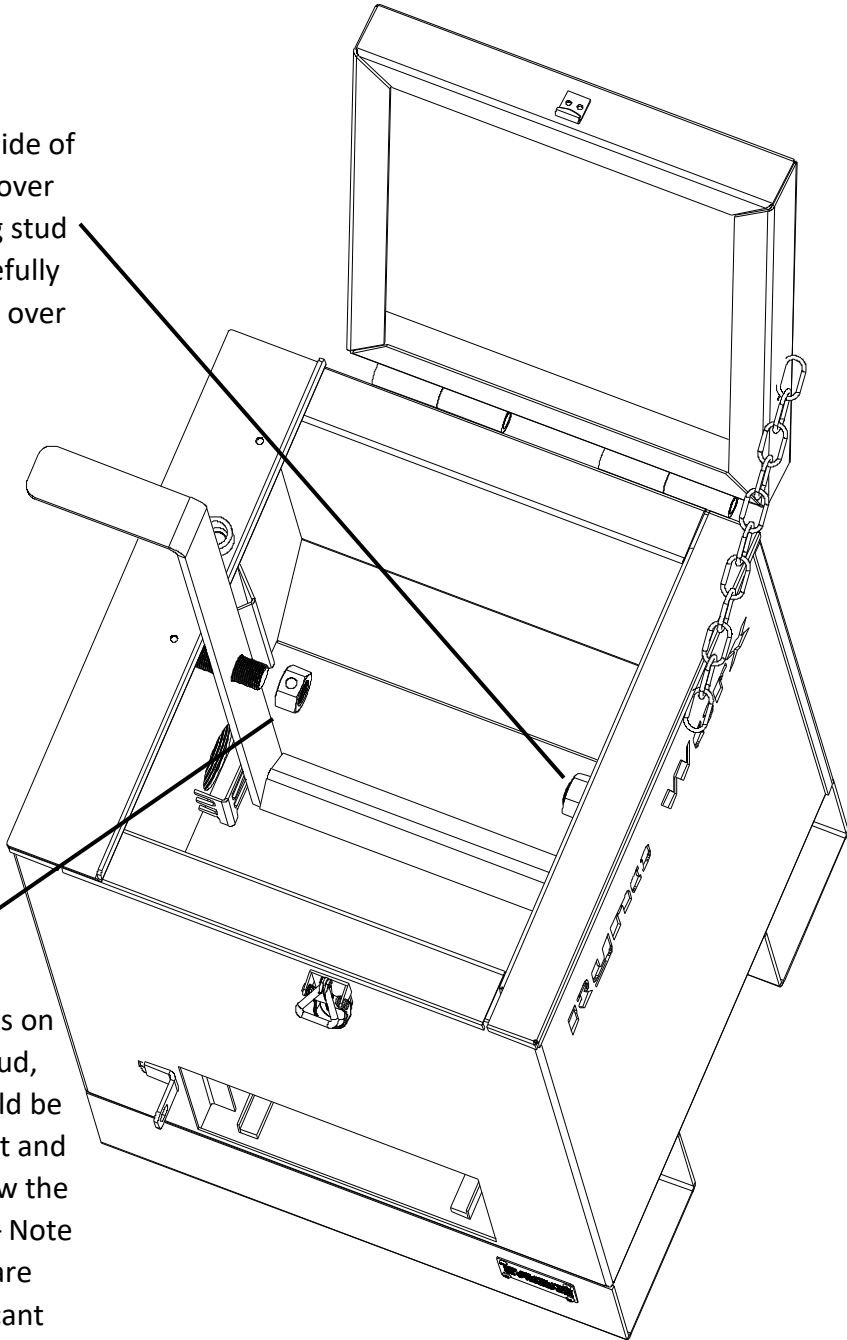

Thread the locknuts on each mounting stud, sufficient play should be left between the nut and agitation bar to allow the bar to swing freely – Note that since these are locknuts, a significant amount of force will be required to thread them on the stud. A long wrench is recommended to make the job easier.

2) Install the Lid Handle

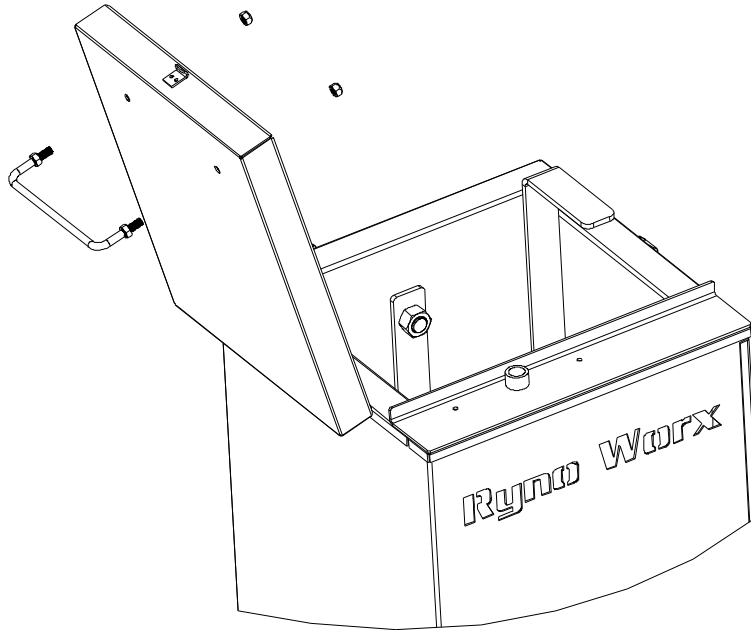

3) Install Thermometer and Thermometer Guard

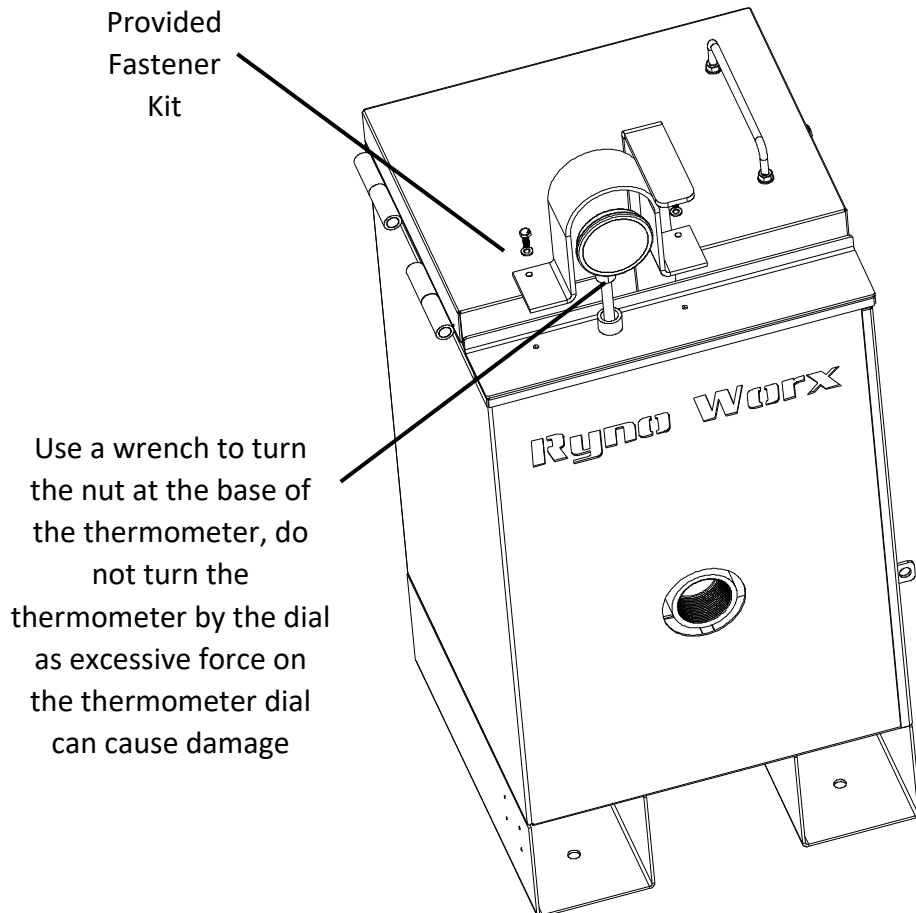

Provided
Fastener
Kit

Use a wrench to turn
the nut at the base of
the thermometer, do
not turn the
thermometer by the dial
as excessive force on
the thermometer dial
can cause damage

4) Thread the Molasses Valve into the Collar

Use a pipe wrench to tighten the valve so that the spout is facing down

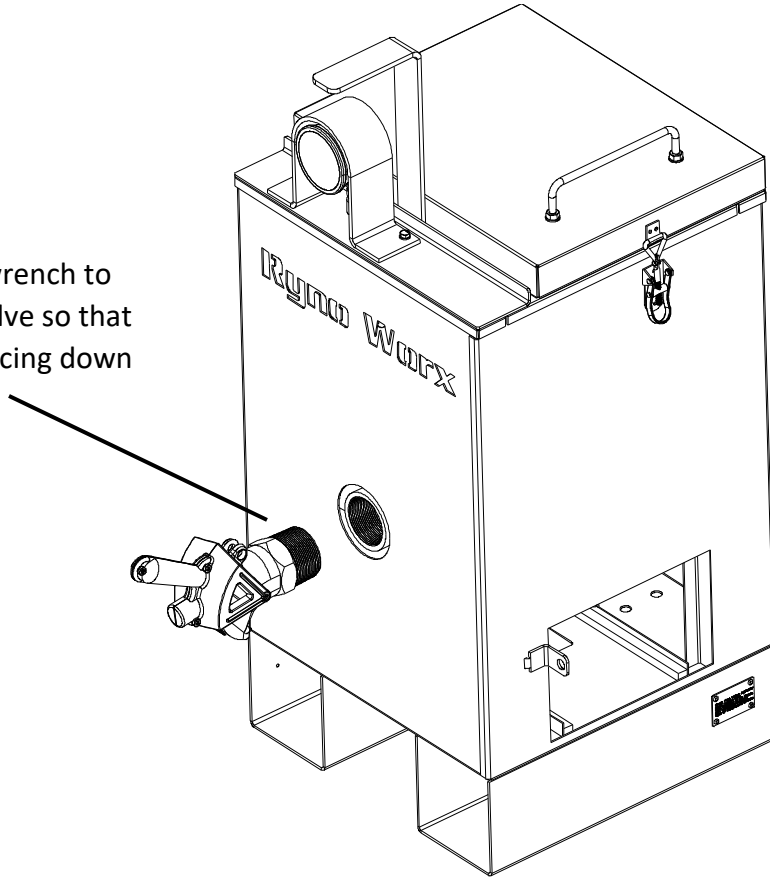

5) Install the AA Battery into the Ignitor

Unscrew the Ignitor Button and Insert a AA Battery (Positive Side Facing Out). Then screw the button back on

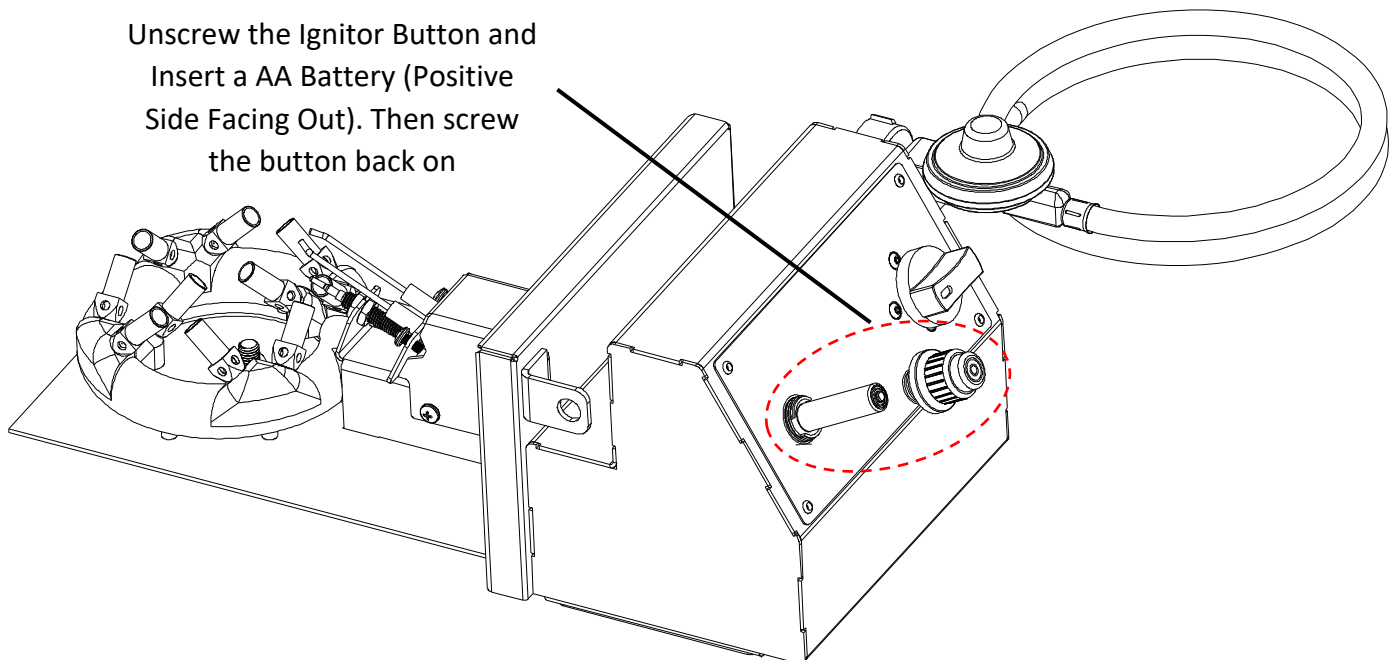

6) Install the Burner Trays

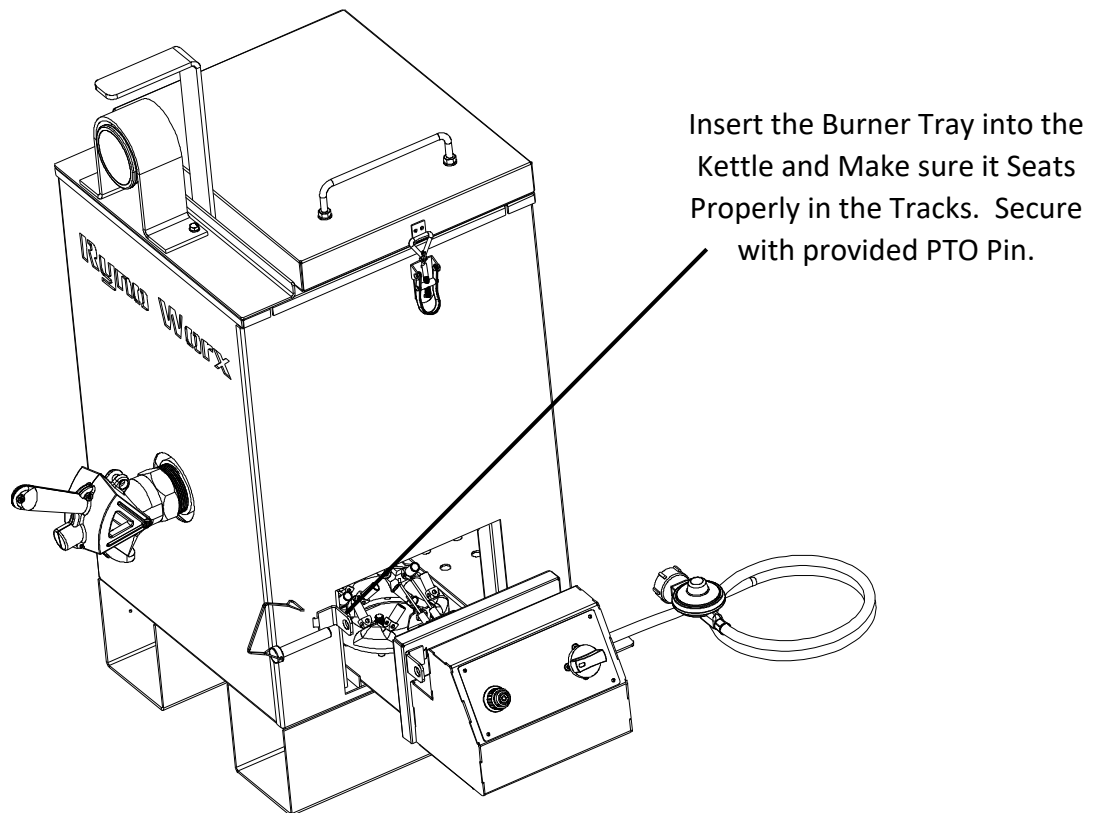

⚠ Make sure the burner trays are secured with the PTO pin at all times, especially during transportation and operation.

⚠ Make sure to secure the propane hoses so that they are clear of the hot kettle walls during operation.

Before beginning please check the following:

1. You have read and understand all warnings on page 2.
2. You are using new and full propane cylinder (use of a used cylinder can lead to reduced performance or equipment failure).
3. You have inspected your regulator, hose and burner assembly and verified there are no leaks or physical damage.
4. You are outdoors in a well-ventilated area that is free and clear of any flammable matter.
5. You have completed the assembly of the equipment correctly.
6. You have 'Direct Fire' type crack sealant such as GemSeal, SealMaster, Durafill, Craftco or Maxwell.
7. There is absolutely NO water in or around the kettle.
8. You are wearing a protective face shield.
9. You are wearing heat and fire resistant protective gloves.
10. You are wearing heat and fire resistant protective clothing which covers all exposed skin.

Part 1 – How to Load and Light your Melter

1. Inspect and ensure there are no leaks between any of the connections before proceeding.
2. Load crack sealant into kettle, while ensuring sealant is resting on the bottom of the kettle.
3. Pullout the burner tray from the kettle.
4. Press and turn the Burner Control Knob counter-clockwise to the Ignite position.
5. Press and hold the Burner Control Knob while simultaneously pressing the Ignitor Button until the burner ignites.
6. Continue holding the Burner Control Knob for 15 – 20 seconds after the burner ignites, this allows the flame-out sensor to heat up and ensure that the burner stays lit.
7. Insert the burner tray back into the kettle and adjust the flame with the Burner Control Knob.
8. Secure the burner tray with the PTO locking pin.

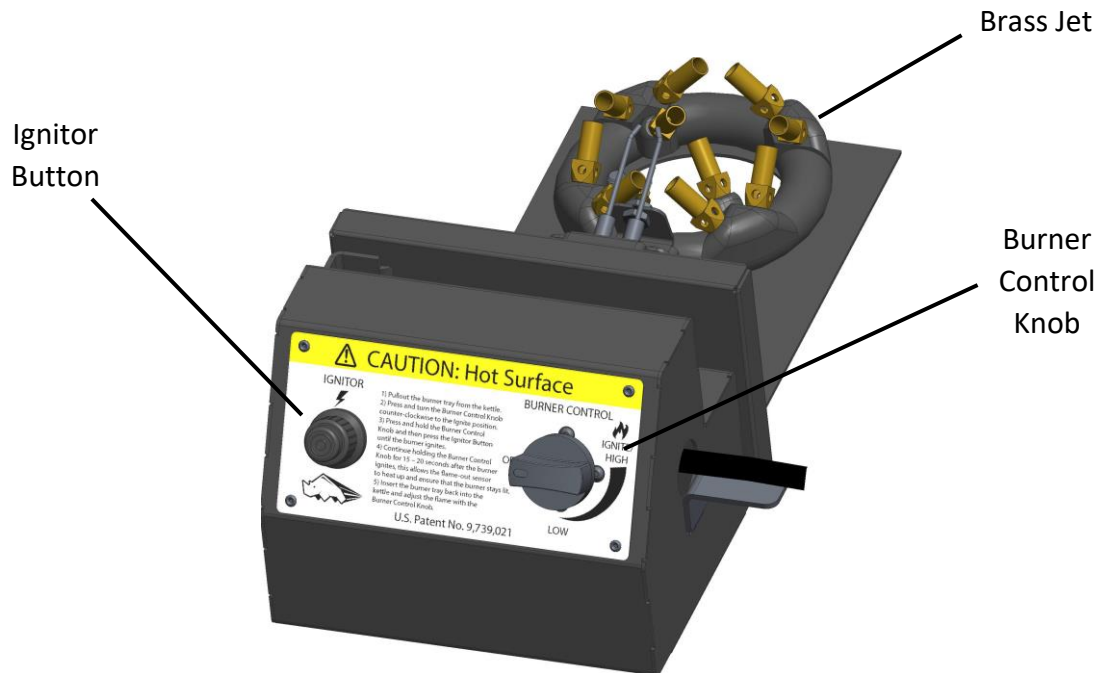

⚠ Never operate the burner if any of the brass jets are missing or damaged.

⚠ Never attempt to tighten brass jets while the burner is lit.

Part 2 – Agitating and Monitoring Temperature

1. Never leave melter unattended when the burner is lit. If flame goes out, promptly turn off the flow of gas; double check that the melter is free and clear of any gas odors before attempting to re-ignite the burner.
 2. While your melter is ignited you should continuously be monitoring the material temperature. Check with your crack sealant manufacturer for safe melting temperatures and ensure you continually adjust the burner control knob to maintain the recommended temperature range. If the material becomes too hot, you may need to turn off your burner periodically.
 3. As material begins to melt, it's important to consistently agitate. Agitation moves the solid crack sealant along the bottom and prevents 'hot spots' from forming which can alter the effectiveness of the sealant after applied. Agitation also prevents chunks of over-heated material from forming which will eventually plug or block your flow valve which can slow down material flow.
-

Part 3 – Dispensing Crack Filler

Once you have effectively liquefied the crack sealant, you may begin to dispense it from the molasses valve into a pour pot or other application device. Having a hot molasses valve helps facilitate the flow of melted crack fill. We recommend having an auxiliary heating torch on hand to heat up the molasses valve before dispensing.

Part 4 – Turning Off and Draining

Once you have finished using the melter, make sure it is fully drained and no crack filler remains inside the kettle or the flow valve. Leaving the flow valve empty after use will prevent the valve from being blocked the next time you use the melter.

- **Periodic Maintenance**

This melter / applicator requires periodic maintenance before each use and at set intervals in order to ensure it is performing safely and optimally. The list below describes checks and maintenance which are recommended.

- Check Propane Tank fuel level, refill as needed.
- Inspect regulator, hose, gas connections, and burner brass jets for physical damage or leaks before every use.
- Periodically inspect thermometer for physical damage or malfunctions.
- Periodically scrape crystallized material from the inside of the kettle.

- **Troubleshooting Guide**

Below we have provided a common problems and solutions table. Be sure to consult this table should you experience any technical problems.

Description of Problem	Possible Causes	Known Solutions
The burner will not ignite or the burner will not stay lit	<ol style="list-style-type: none"> 1) The electric ignition may have dead or low power batteries 2) Burner control button is not being held long enough for ignition to take place 3) The fuel level could be too low 4) The propane cylinder valve could be partially or fully closed, which can restrict fuel flow 	<ol style="list-style-type: none"> 1) Change the batteries located in the ignitor assembly, double check spark. 2) Ensure you hold your burner control button until the burner ignites, continue to hold for an additional 15-20 seconds 3) Check and refill your fuel tank 4) Ensure your fuel valve is fully open, you can do this by turning the knob fully counter-clockwise
Crack filler is hot, but will not come out of the flow valve	<ol style="list-style-type: none"> 1) Crack filler was left inside the melter from a previous job. This crack filler has solidified inside the molasses valve and although the material in the kettle is melted, the material in the molasses valve may not be. 	<ol style="list-style-type: none"> 1) Allow the burner more time to heat up the valve until the crack filler inside begins to melt. Alternatively, you may heat up the valve using a propane torch assembly.
Burner will not stay lit	<ol style="list-style-type: none"> 1) The fuel level may be too low 2) Loose connection between the thermocouple and flame-out valve 	<ol style="list-style-type: none"> 1) Refill your fuel tank 2) Tighten the thermocouple connection to the flame-out valve
Crack filler is melting really slowly	<ol style="list-style-type: none"> 1) Incorrect crack sealant being used 2) Burner is not providing enough heat to melt the crack sealant 3) The temperature outside is cooler than normal slowing down the melting process 	<ol style="list-style-type: none"> 1) Double check that you are using an approved crack sealant for use in direct-fire melters 2) Increase the fuel to your burner 3) No solutions, melting takes longer on cooler days